



Data Sheet

Customer: _____
Part No: CL-SP0201DLG-02
Sample No: _____
Description: _____
Item No: _____

Customer			
Check	Inspection	Approval	Date

Features

- .0201 package
- .Top view LED
- .Compatible with infrared and vapor phase reflow solder process.
- .Pb-free
- .RoHS compliant

Description

.The Ciellight 0201 package has high efficacy, high power consumption, wide viewing angle and a compact form factor.

.These features make this package an ideal LED for all lighting applications.

Applications

- .General lighting
- .Decorative and Entertainment Lighting
- .Indicators
- .Automotive Telecommunication
- .Switch lights

Device Selection Guide

Chip Material	Emitted Color	Resin Color
AlGaInP	Brilliant Green	Water Clear

Absolute Maximum Ratings (Ta=25°C)

Parameter	Symbol	Rating	Unit
Continuous Forward Current	I_F	25	mA
Operating Temperature	T_{opr}	-40 ~ +85	°C
Storage Temperature	T_{stg}	-40 ~ +100	°C
Peak Forward Current (Duty 1/10@1ms)	I_{FP}	60	mA
Soldering Temperature* ¹	T_{sol}	Reflow Soldering : 260 °C for 10 sec. Hand Soldering : 350 °C for 3 sec.	
Power Dissipation at(or below) 25°C Free Air Temperature	P_d	95	mW
Electrostatic Discharge(HBM)	ESD	2000	V

Notes: *1: Soldering time \leq 5 seconds

Electro-Optical Characteristics (Ta=25°C)

Parameter	Symbol	Min.	Typ.	Max.	Unit	Condition
Forward Voltage	V_F	2.8	---	3.3	V	$I_F=20mA$
Reverse Current	I_R	---	---	10	μA	$V_R=5V$
Luminous Intensity	I_v	300	---	600	mcd	$I_F=20mA$
Viewing Angle	$2\theta_{1/2}$	---	120	---	deg	$I_F=20mA$

Notes:

1. Tolerance of Luminous Intensity $\pm 10\%$.
2. Tolerance of Forward Voltage : $\pm 0.05V$.

Bin Range of Luminous Intensity

Bin Code	Min	Max	Unit	Condition
G1	300	400	mcd	I _F =20mA
G2	400	500		
G3	500	600		

Note:

 Tolerance of Luminous Intensity: $\pm 10\%$.

Bin Range of Forward Voltage

Bin Code	Min	Max	Unit	Condition
1	2.8	2.9	V	I _F =20mA
2	2.9	3.0		
3	3.0	3.1		
4	3.1	3.2		
5	3.2	3.3		

Note:

 Tolerance of Forward Voltage: $\pm 0.05\text{V}$.

Bin Range of Dominant Wavelength

Bin Code	Min	Max	Unit	Condition
G1	522	524	nm	I _F =20mA
G2	524	526		
G3	526	528		
G4	528	530		

Note:

 Tolerance of Dominant Wavelength: $\pm 1\text{nm}$.

Package Dimensions

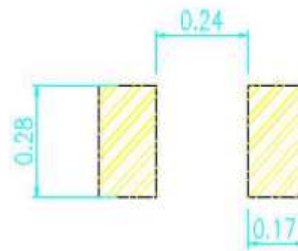
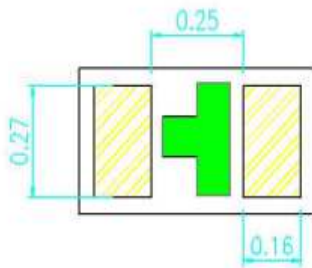
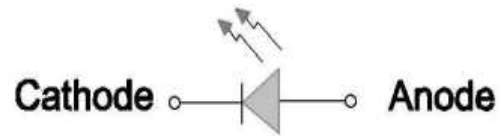
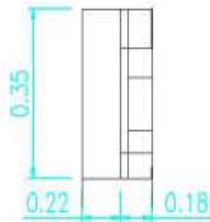
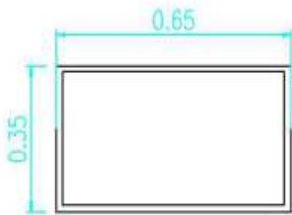
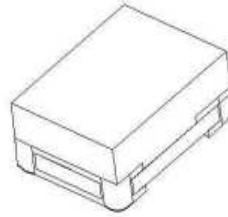
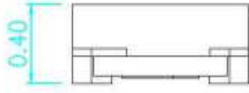

Soldering PAD

Note: Tolerance unless mentioned is ± 0.1 mm, Unit = mm.

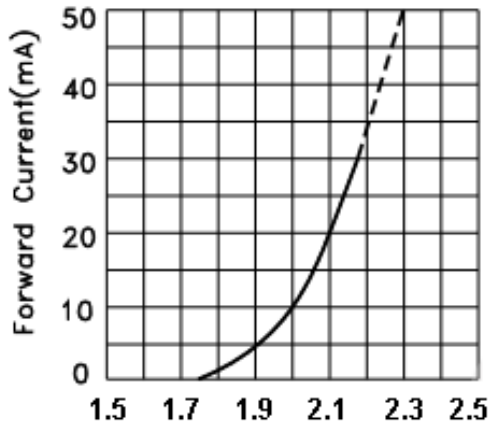

Forward current Vs. Forward voltage

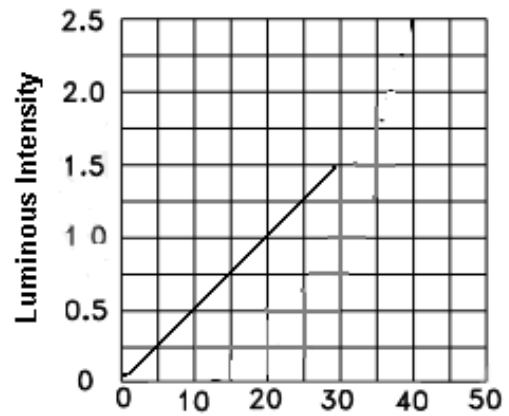

Luminous Intensity Vs. Forward current

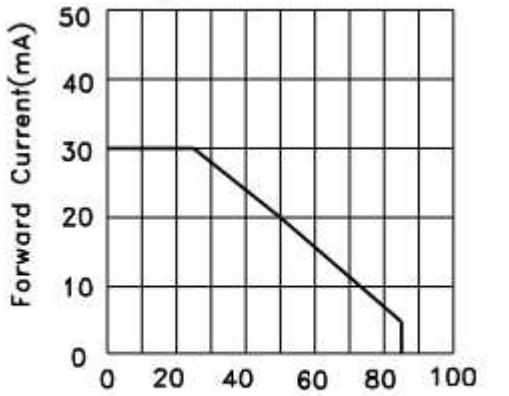

Ambient Temperature T_A (°C)
FORWARD CURRENT
DERATING CURVE

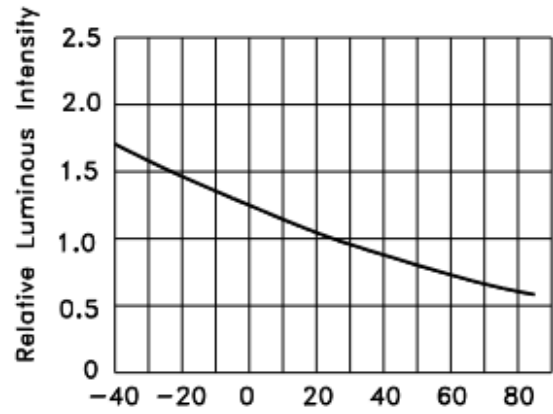

Ambient Temperature T_A (°C)
LUMINOUS INTENSITY Vs.
AMBIENT TEMPERATURE

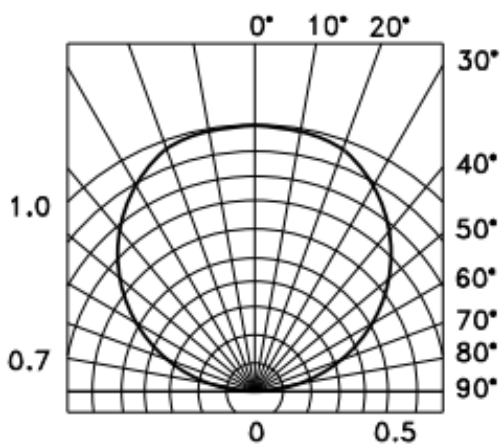

SPATIAL DISTRIBUTION

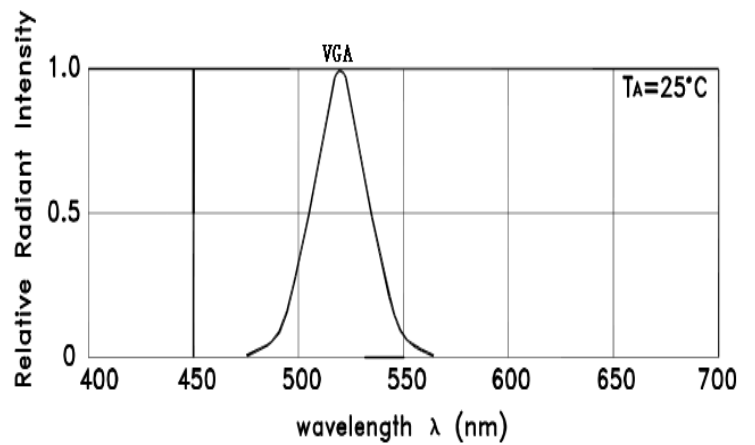

RELATIVE INTENSITY Vs. WAVELENGTH

Label Form Specification

CPN: Customer's Production Number

P/N : Production Number

QTY: Packing Quantity

CAT: Ranks

HUE: Peak Wavelength

REF: Reference

LOT No: Lot Number

Reel Dimensions

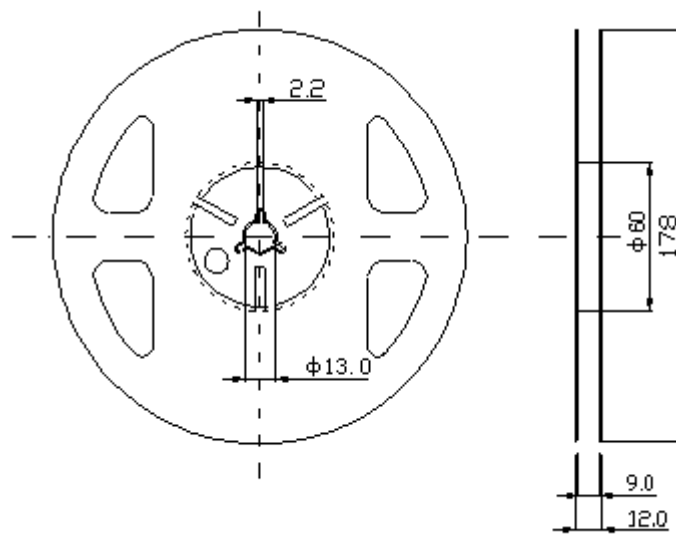

Note: The tolerances unless mentioned is $\pm 0.1\text{mm}$,Unit = mm

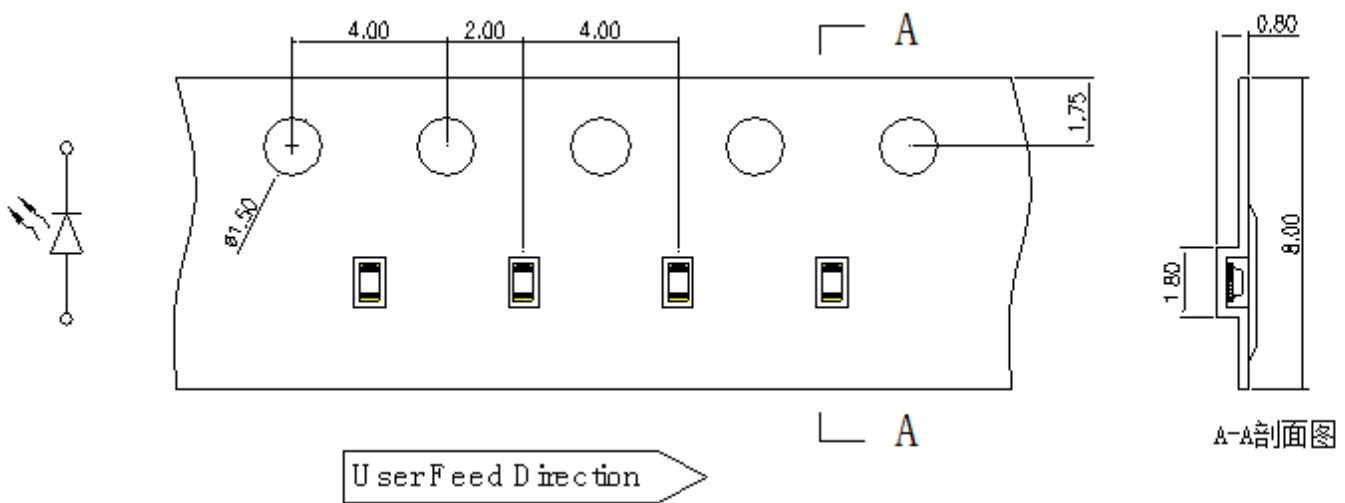

Moisture Resistant Packing Process

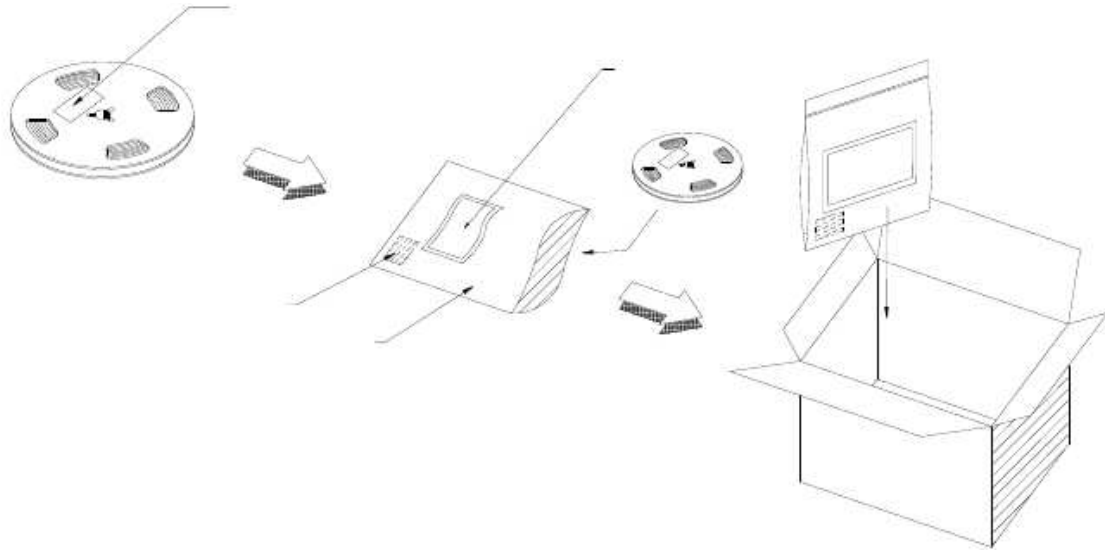

Reliability Test Items and Conditions

The reliability of products shall be satisfied with items listed below.

Confidence level: 90%

LTPD: 10%

No.	Items	Test Condition	Test Hours/Cycles	Sample Size	Ac/Re
1	Reflow Soldering	Temp. : 260°C/10sec.	6 Min	22 PCS	0/1
2	Thermal Shock	H : +100°C 5min ∫ 10 sec L : -10°C 5min	300 Cycles	22 PCS	0/1
3	Temperature Cycle	H : +100°C 15min ∫ 5 min L : -40°C 15min	300 Cycles	22 PCS	0/1
4	High Temperature/Humidity Reverse Bias	Ta=85°C,85%RH	1000 Hrs.	22 PCS	0/1
5	Low Temperature Storage	Ta=-40°C	1000 Hrs.	22 PCS	0/1
6	High Temperature Storage	Ta=100°C	1000 Hrs.	22 PCS	0/1
7	DC Operation Life	Ta=25°C IF = 20 mA	1000 Hrs.	22 PCS	0/1

Precautions For Use

1. Over-current-proof

Customer must apply resistors for protection , otherwise slight voltage shift will cause big current change (Burn out will happen).

2. Storage

- 2.1 Do not open moisture proof bag before the products are ready to use.
- 2.2 Before opening the package, the LEDs should be kept at 40°C or less and 90%RH or less.
- 2.3 The LEDs should be used within a year.
- 2.4 After opening the package, the LEDs should be kept at 30°C or less and 60%RH or less.
- 2.5 The LEDs should be used within 168 hours (7 days) after opening the package
- 2.6 If the moisture absorbent material (silica gel) has faded away or the LEDs have exceeded the storage time, baking treatment should be performed using the following J-STD-33 Standard.

3. Soldering Condition

3.1 Pb-free solder temperature profile

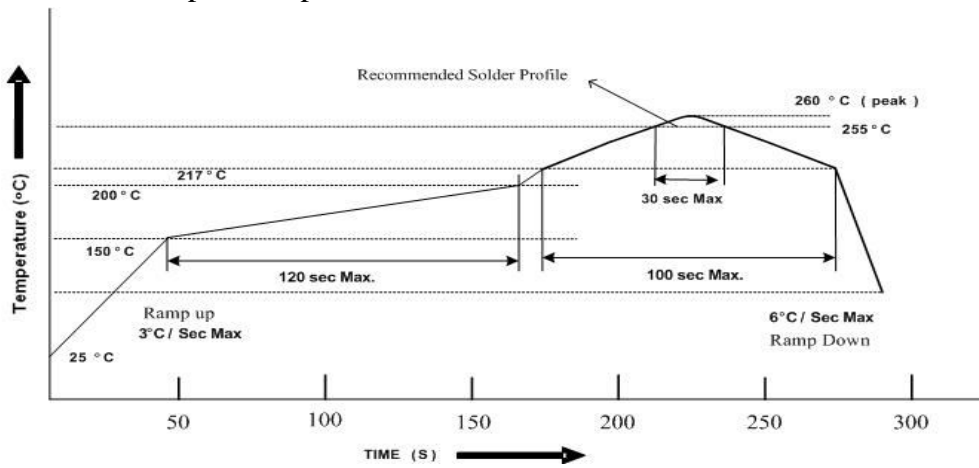

- 3.2 Reflow soldering should not be done more than two times.
- 3.3 When soldering, do not put stress on the LEDs during heating.
- 3.4 After soldering, do not warp the circuit board.

4. Soldering Iron

Each terminal is to go to the tip of soldering iron temperature less than 350°C for 3 seconds within once in less than the soldering iron capacity 25W. Leave two seconds and more intervals, and do soldering of each terminal. Be careful because the damage of the product is often started at the time of the hand solder.

5. Repairing

Repair should not be done after the LEDs have been soldered. When repairing is unavoidable, a double-head soldering iron should be used (as below figure). It should be confirmed beforehand whether the characteristics of the LEDs will or will not be damaged by repairing.