

SAMPLE APPROVE SHEET

Customer Name: _____

Product model : 3535 1 -3W 940nm

Product encoding : CL-SFD3535IR-940-05(1,3W 공용)

Issue Date : _____ 2022-07-26 _____

Lens Color Code	C Water Transparent
	T Colored Transparent
	D White Diffused
	E Colored Diffused

Customer confirmation	Checked by	Prepared by

Exterior:

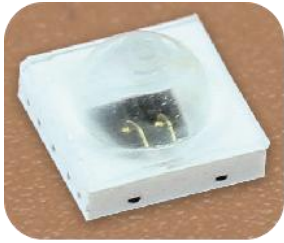

Product conformation:

Packaging glue: colorless transparent silica gel

Packaging bracket:3535 emc

Luminous color: Infrared (invisible light)
wavelength 940nm

Chip specification: jing yuan 28mil-d*28mil-d

Luminous Angle: 120 degrees

Electrostatic sensitive material

Applications:

infrared applications systems

infrared illumination for cameras

secunrity monitoring

wireless communication

Radiation Pattern

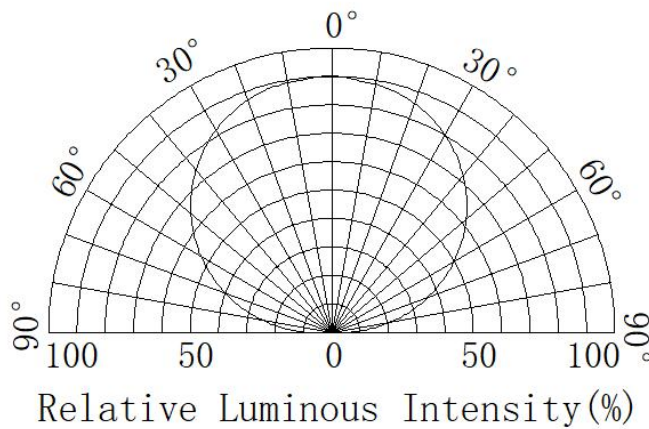

Typical Optical/ Electrical Characteristics @T_J=25°C

Parameter	Symbol	Condition	Min	Typ	Max	Unit
Luminous power	P _o	IF=350mA	150	200	230	mW
		IF=700mA	200	250	300	
Luminous intensity	I _e	IF=350mA	70	80	90	mW/Sr
		IF=700mA	100	130	160	
Emission Angle	2 θ 1/2	--	--	120	--	Deg
Wavelength	λ _p	IF=350mA	930	940	950	nm
Half wave width	Δλ	IF=350mA	--	35	--	nm
Forward Voltage	V _F	IF=350mA	1.4	-	2.0	V
		IF=700mA	1.5	-	2.3	
Reverse current	I _R	VR=5.0V	-	--	10	μA

- Notes: 1. Tolerance of measurement of forward voltage ±0.1V.
 2. Tolerance of measurement of peak Wavelength ±2.0nm.
 3. Tolerance of measurement of luminous intensity ±5%.

Absolute Maximum Rating

Electrical characteristics	Symbol	Rated Value	Unit	condition Temperature
Max continuous working current	IF	≤700	mA	T _a =25°C
Max pulse current	IFP	3	A	T _a =25°C
Reverse breakdown voltage	VR	5	V	T _a =25°C
Operating Temperature	T _{opr}	-40°C to +100°C	°C	
Storage Temperature	T _{stg}	-40°C to +100°C	°C	
Circle solder Temperature	T _{sol}	245°C for 10sec	°C	
complete Temperature	T _j	115	°C	

*IFP Conditions: Pulse Width ≤ 10msec duty ≤ 1/10

* All high power emitter LED products mounted on aluminum metal-core printed circuit board, can be lighted directly, but we do not recommend lighting the high power products for more than 5 seconds without a appropriate heat dissipation equipment.

*Re-flow, wave peak and soak-stannum soldering etc. is not suitable for this products.

*Suggest to solder it by professional high power LED soldering machine.

*Can use invariable-temperature searing-iron with soldering condition : ≤ 260 degree less than 3 seconds.

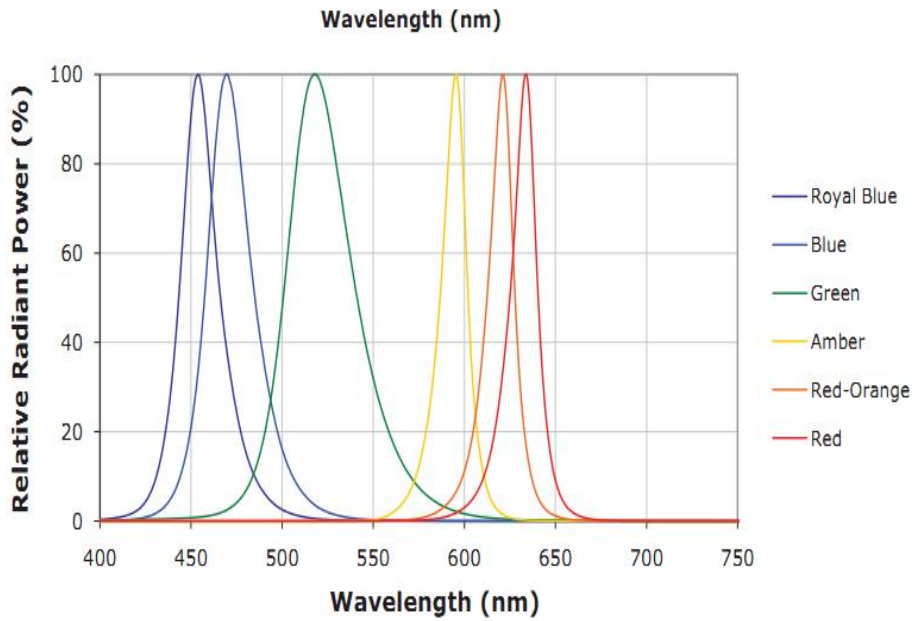
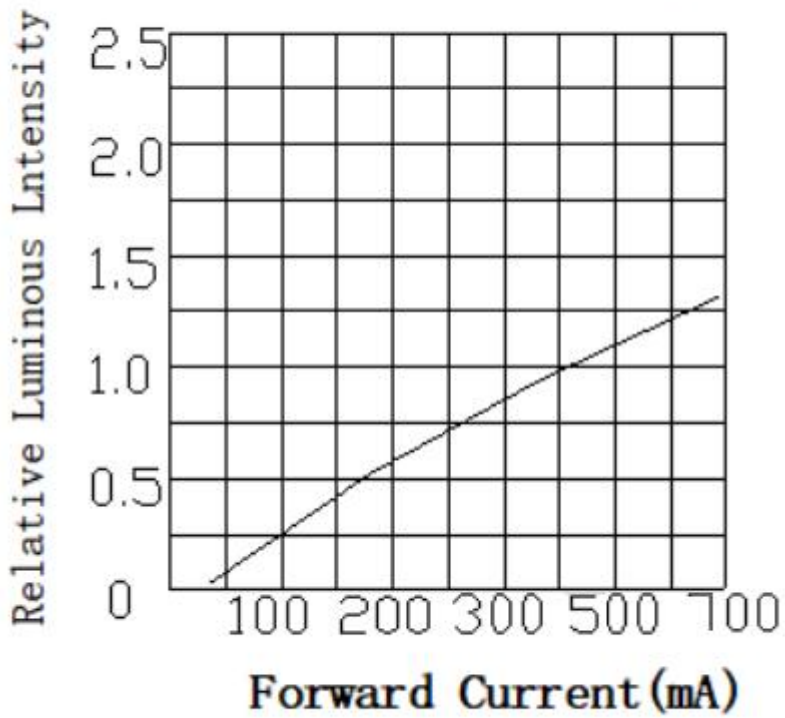
Wavelength Characteristics

Forward Current VS. Relative Intensity

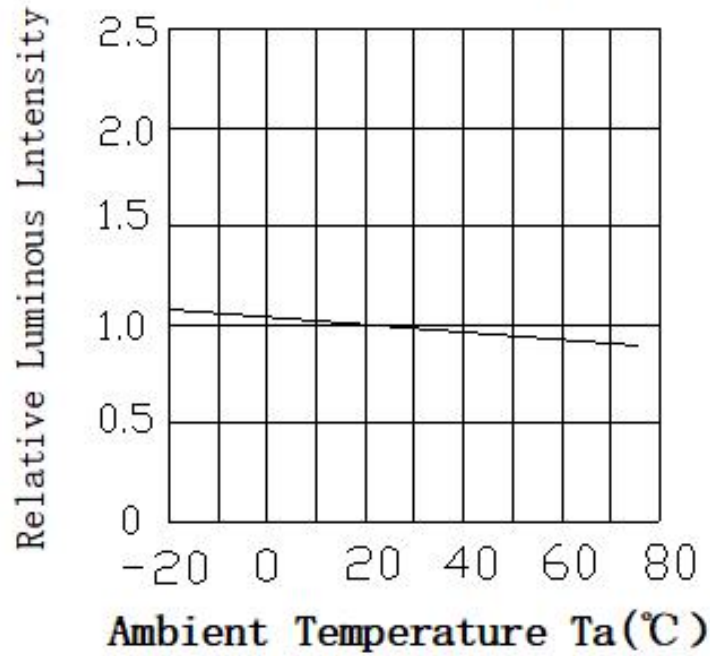
**Ambient Temperature VS
Relative Intensity**

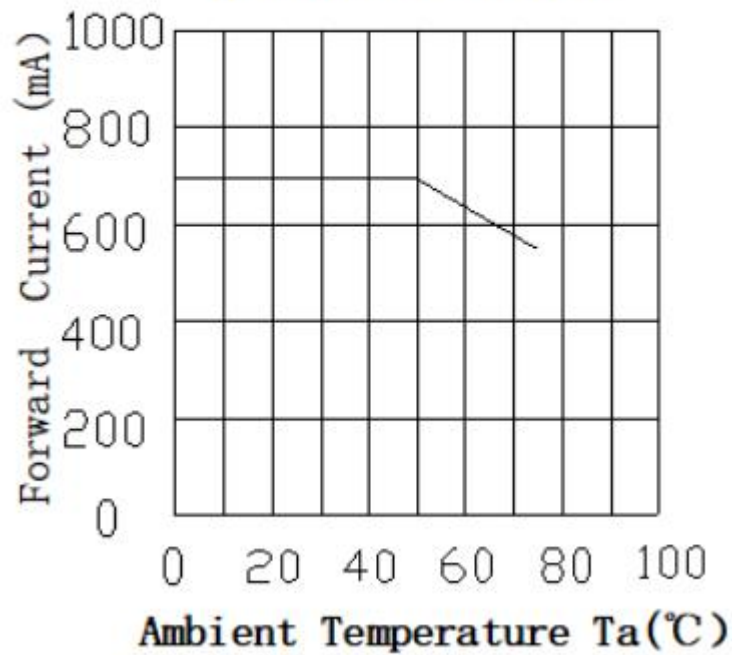

**Ambient Temperature .
VS Forward Current**

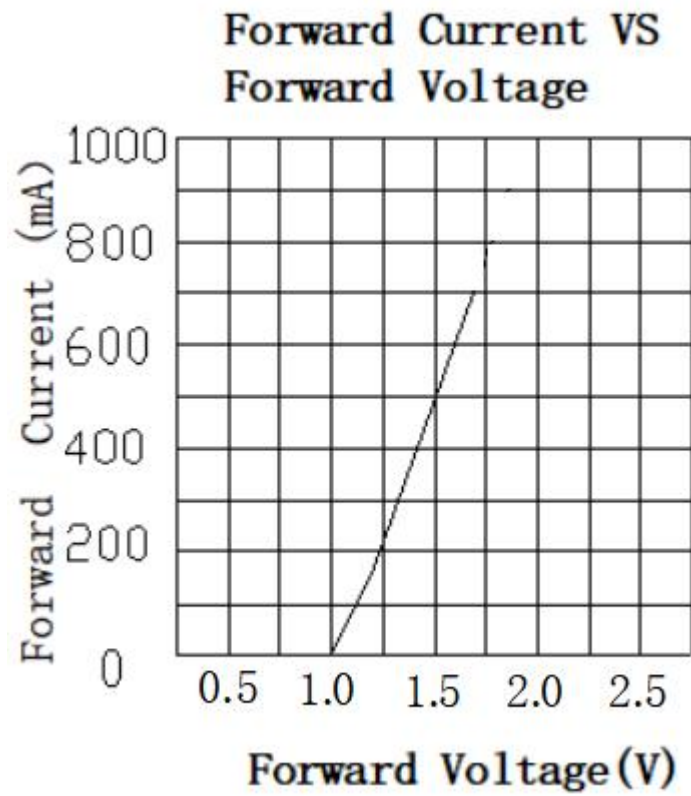



The connection method of chips :

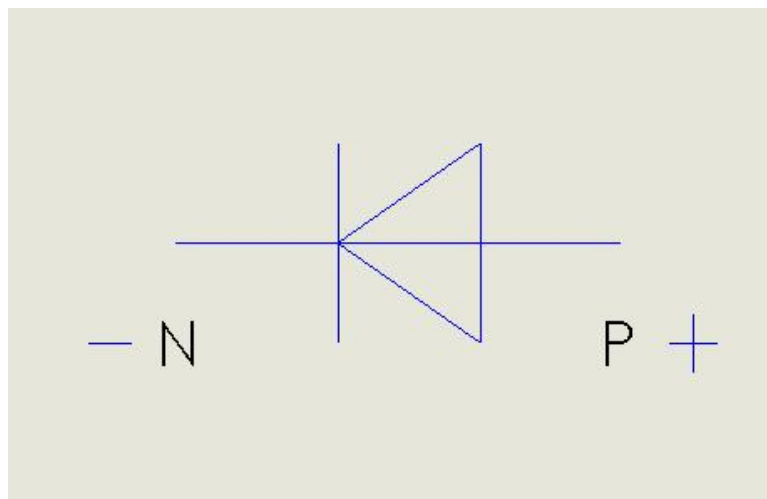

Package Dimensions (MM)

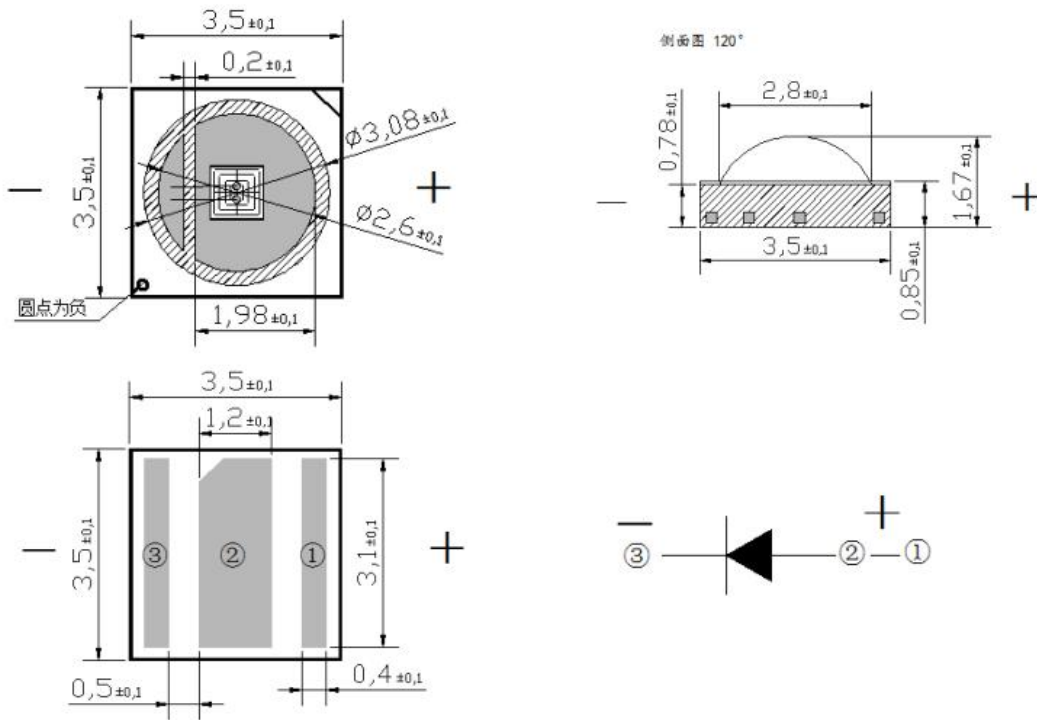

Recommended Soldering Patter (MM)

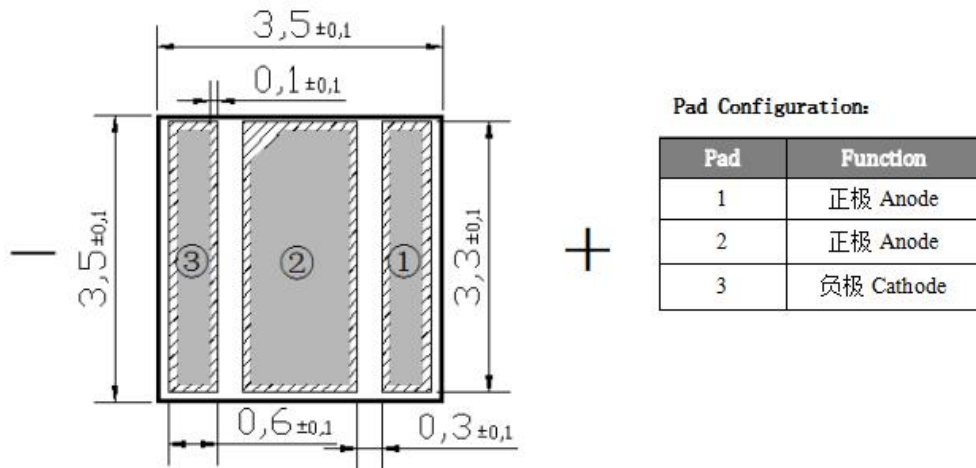

- Notes:
1. All dimension units are millimeters.
 2. All dimension tolerance is ± 0.2 mm unless otherwise noted.
 3. The brass column of heat sink of the high power LED is Anode. Please pay more attention to the necessary installation, when installing The heat dissipate on equipments and connecting the electric circuit in avoid of short circuit and destroying

Reel Dimensions:

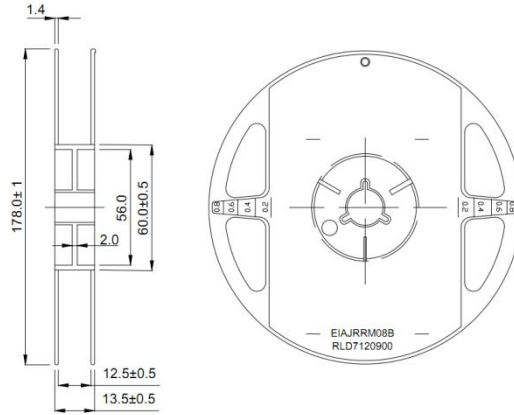

Progressive direction and Dimensions:

Loaded quantity 1000PCS per reel

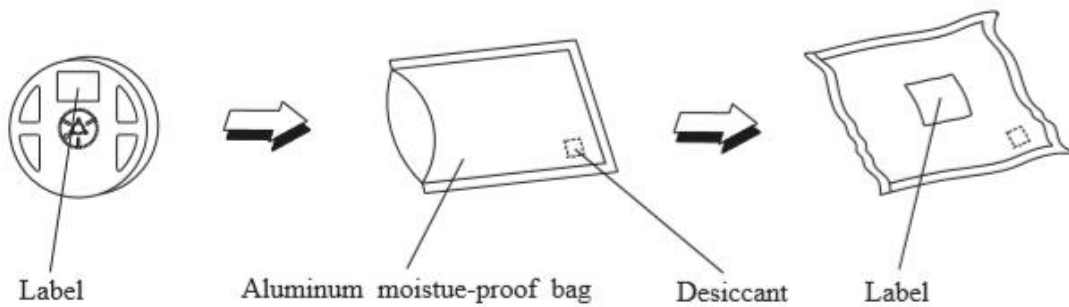
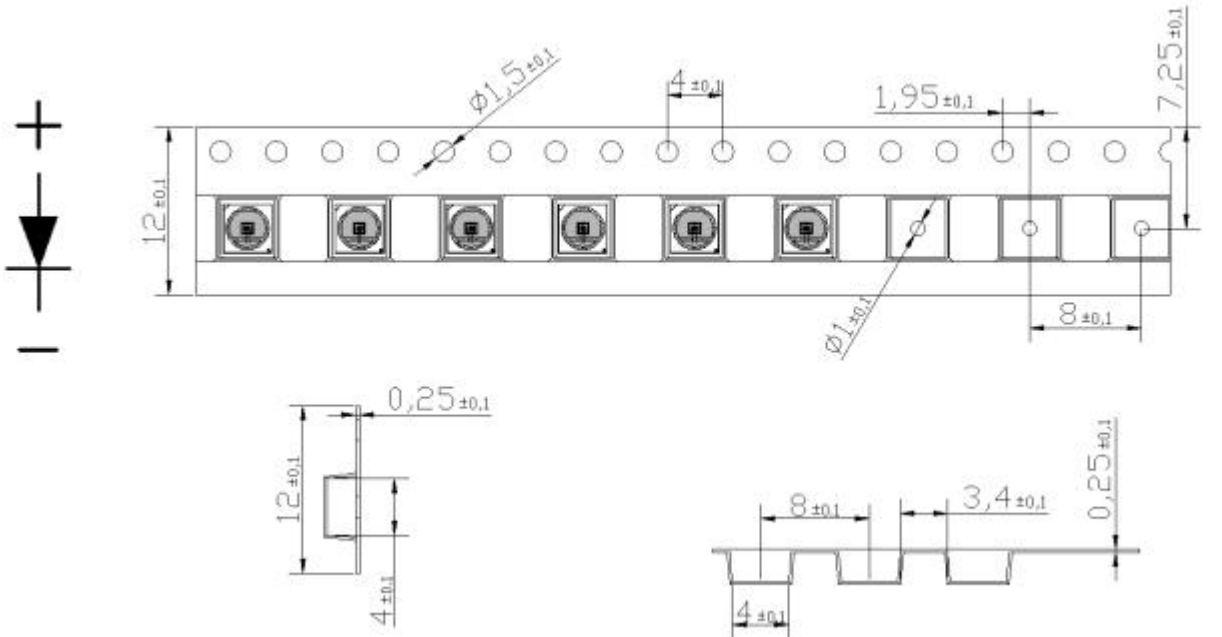

Product access and installation:

Before opening the electrostatic shielding bag, it is required to confirm whether the working table and production equipment are grounded. The operator shall wear electrostatic bracelet, gloves or fingertips for operation. After opening the package, the operator should use tweezers to hold both sides of the lamp bead to avoid direct contact with the front cover plate of the lamp bead. The workplace should be free of VOC pollution. Unnecessary pollution will lead to the strong absorption of the UV emitted from the front and affect the light power.

The lamp bead cover plate is a fragile component. Knocking, vibration, prying, clamp and other operations are easy to cause the cover plate to break and affect the use.

*** welding of products:**

It is recommended to use low temperature solder paste for reflow welding, and the temperature curve can refer to the following figure:

Note:

- 1) The actual temperature curve shall depend on the type, proportion and Different reflow soldering equipment, substrate materials, etc And adjustment;
- 2) It is recommended to do more tests before batch welding to ensure the best workers are used Art curve;
- 3) Improper return temperature and time may cause the bead surface The discoloration of the coating may cause the LED chip in the lamp bead to be desoldered and fail;
- 4) After reflow welding, the lamp beads should not be repaired again. When repair is inevitable, double head soldering iron must be used, and it is necessary to confirm in advance whether this way damages the characteristics of the lamp bead itself.

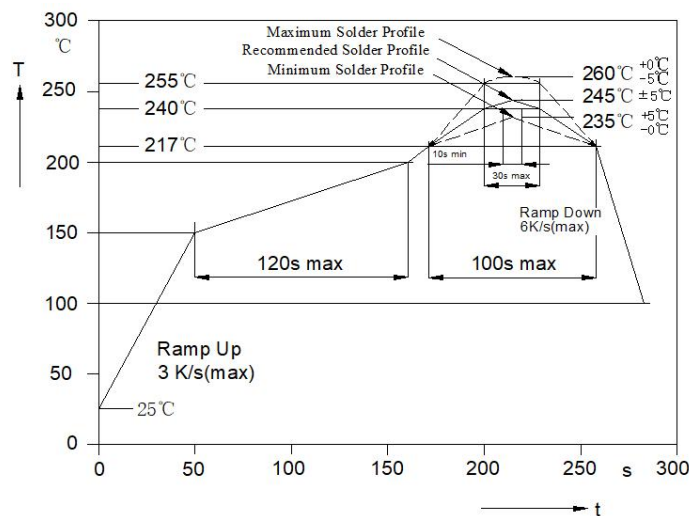

specific definition of each temperature zone in the figure:

Preheating zone: the heating rate is 1.0-3.0 °C / s, and the heating rate is too fast in the preheating zone, which is easy to make the mobility and composition of solder paste worsen, and easy to produce the phenomenon of tin explosion and solder bead.

Soakage zone: temperature 110-130 °C, time 90-100s, if the temperature is too low, there will be solder not melting after reflow (recommended temperature rise rate < 2 °C / S)

Back welding area: the peak temperature shall be set at 170-180 °C. It is recommended to adjust the melting time above 138 °C to 50-80 seconds.

Cooling zone: cooling rate < 4 °C / S

Special note:

1 for any other matters not mentioned in this specification, please call our sales department.

2 important safety tips:

This product will produce deep ultraviolet after correct operation and power on, and direct irradiation may cause harm to human skin and eyes. It is recommended to wear protective clothing, gloves and goggles during operation / use. It is strictly prohibited to directly irradiate the ultraviolet without taking protective measures, and it is strictly prohibited to directly look at the ultraviolet without wearing protective glasses.

