



Data Sheet

Customer: _____
Part No: CL-SFC606IR-850-01 _____
Sample No: IR SMD _____
Description: _____
Item No: _____

Customer			
Check	Inspection	Approval	Date



Features:

- . High radiant power and high radiant intensity.
- . Low forward voltage.
- . Good Reliability and Long Life
- . Soldering methods: reflow soldering
- . This product doesn't contain restriction substance, comply ROHS standard
- . Pb free

Applications

- . Remote Control.
- . Smoke detector
- . Infrared applications systems
- . Infrared remote control emission



Description

- . This infrared LED is a low power consumption diode in SMD package.
- . This model has the advantages of strong transmitting power and uniform light angle.
- . The device is spectrally matched with phototransistor, photodiode and infrared receiver module.

Package Dimensions in millimeters

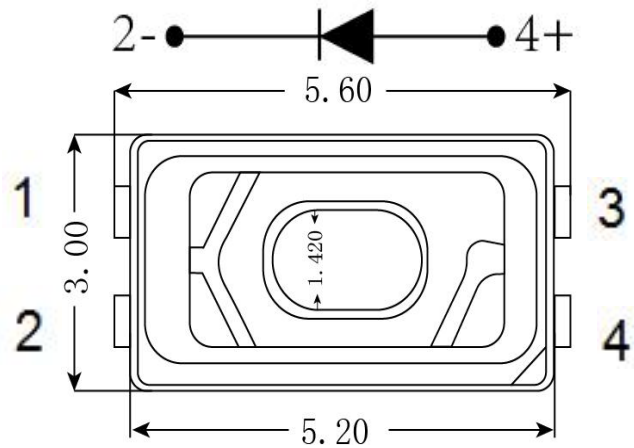
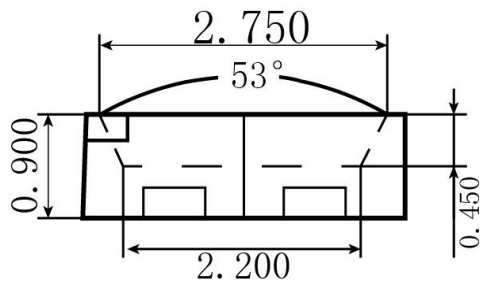

Recommended Soldering Pattern:
(Units : mm.)

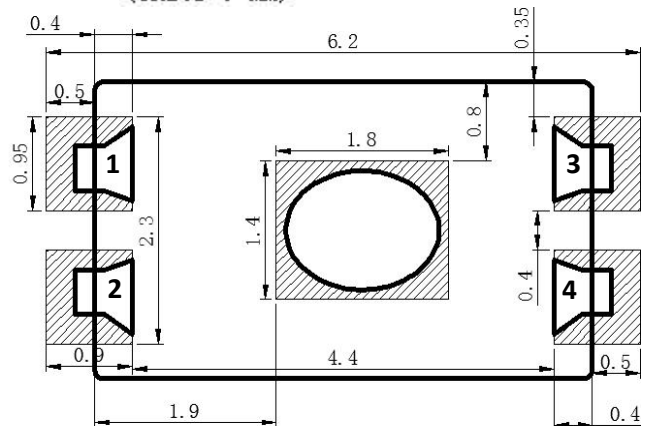
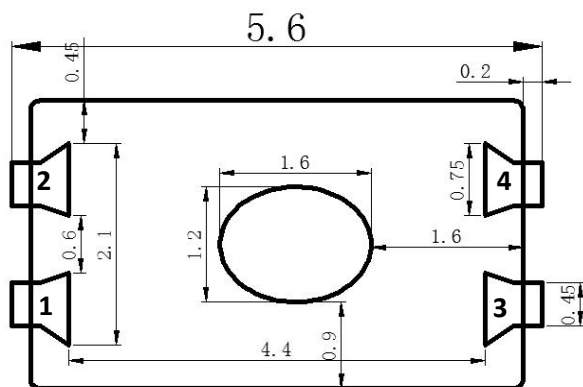

Notes:

1. All dimensions are in millimeters.
2. All dimension tolerance is $\pm 0.2\text{mm}$ unless otherwise noted.
3. Specifications are subject to change without notice

Selection Guide

Part No.	Chip Materials	Lens Type
CL-SFC606IR-850-01	AlGaAs/GaAs	Water clear

Electrical And Optical Characteristics (Ta=25°C)

Parameter	Symbol	Min	Typ.	Max	Units	Condition
Radiant Intensity	I _e	-	12	-	mW/sr	IF=60mA
		-	20	-	mW/sr	IF=100mA
Forward Voltage	V _F	1.3	-	1.8	V	IF=60mA
Reverse Current	I _R	-	-	10	uA	V _R =5V
Peak Wavelength	λ _p	840	850	870	nm	IF=60mA
Controlled Angle	2θ _{1/2}	-	120	-	deg	IF=60mA

Note:

1. 2θ_{1/2} is the angle from optical centerline where the luminous intensity is 2θ_{1/2} the optical centerline value.
2. the above luminous intensity measurement allowance tolerance ±10%

Absolute Maximum Ratings (Ta=25°C)

Parameter	Symbol	Ratings	Units	Notice
Continuous Forward Current	I _F	100	mA	--
Power Dissipation	P _D	180	mw	--
Reverse Voltage	V _R	5	V	--
Operating Temperature	T _{opr}	-20~+80	°C	--
Storage Temperature	T _{stg}	-40~+100	°C	--
Soldering Temperature	T _{sd}	260 (<10sec)	°C	--

Note:

1/10 Dut cycle,0.1ms pulse width.

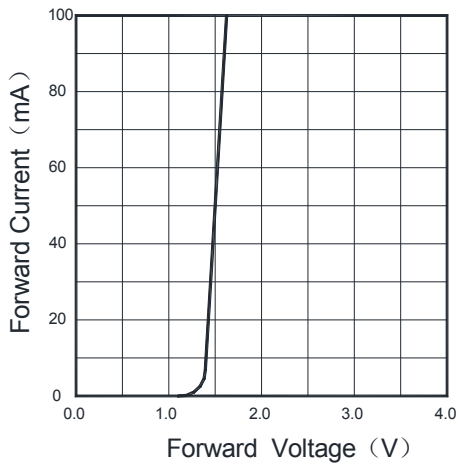
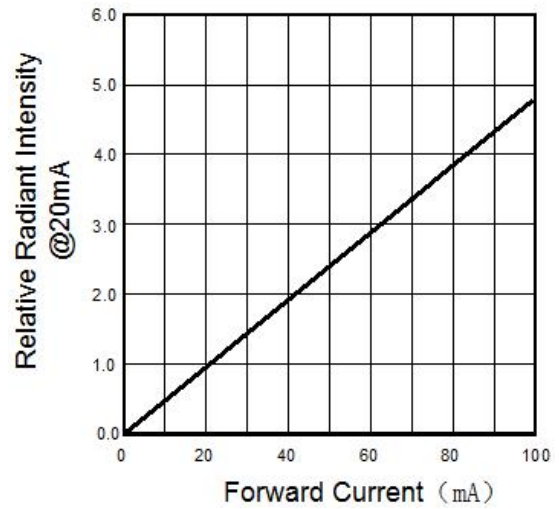
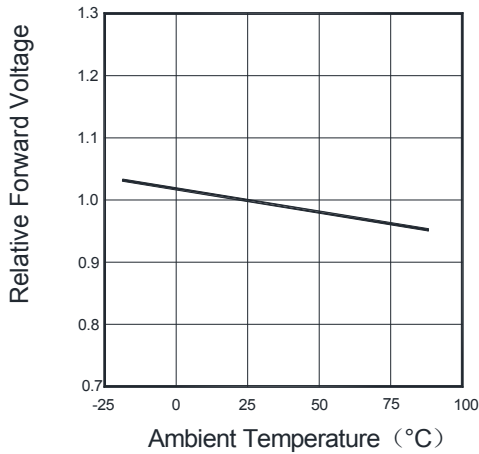
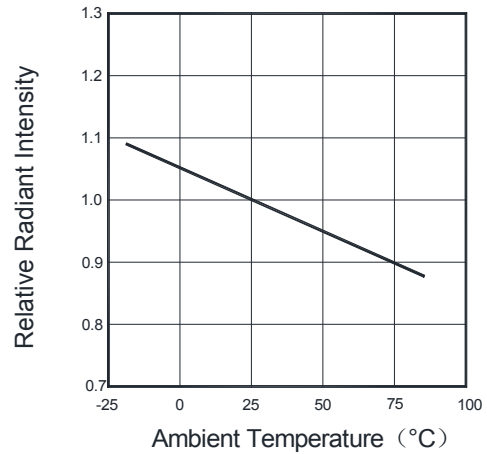
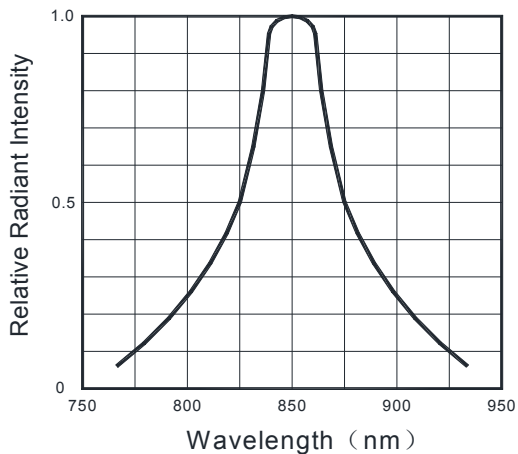
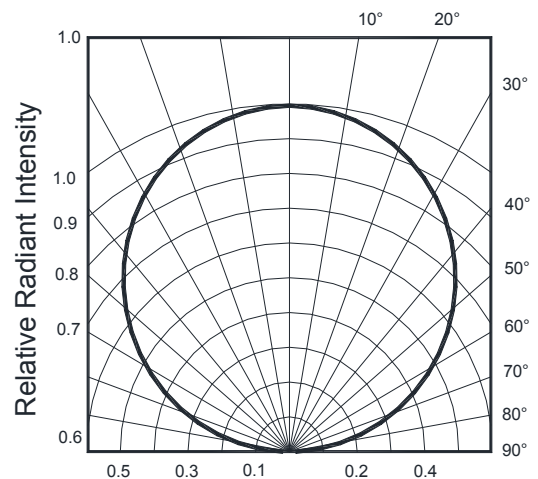
Typical Optical-Electrical Characteristic Curves
Fig.1 Forward Current Vs Forward Voltage

Fig.2 Relative Radiant Intensity Vs Forward Current

Fig.3 Relative Forward Voltage Vs Ambient Temperature

Fig.4 Relative Radiant Intensity Vs Ambient Temperature

Fig.5 Spectral Distribution

Fig.6 Radiant Diagram

Reliability Test Item And Condition

Test Item	Test Condition	Time	Quantity	Ac/Re
Life Test	Ta=25°C±5°C IF=60mA	1000H	22	0/1
High Temperature Life Test	Ta=85°C±5°C IF=60mA	1000H	22	0/1
Storage at High Temperature	Ta=100±5°C	1000H	22	0/1
Storage at Low Temperature	Ta=-40±5°C	1000H	22	0/1
Storage at High Temperature/High Humidity	Ta:85±5°C,RH:85±5%	1000H	22	0/1
Temperature cycle	100°C~25°C~-40°C~25°C (30min)(5min)(30min) (5min)	100 Cycles	22	0/1
Red ink	Ta=100±5°C	2H	22	0/1
Reflow soldering	Temp:260°C max T=10 sec	3 times	22	0/1

The technical information shown in the data sheets are limited to the typical characteristics and circuit examples of the referenced products.It does not constitute the warranting of industrial property nor the granting of any license.

SMT Reflow Soldering Instructions SMT

- 1.Reflow soldering should not exceed once
- 2.When soldering , do not put stress on the LEDs during heating .

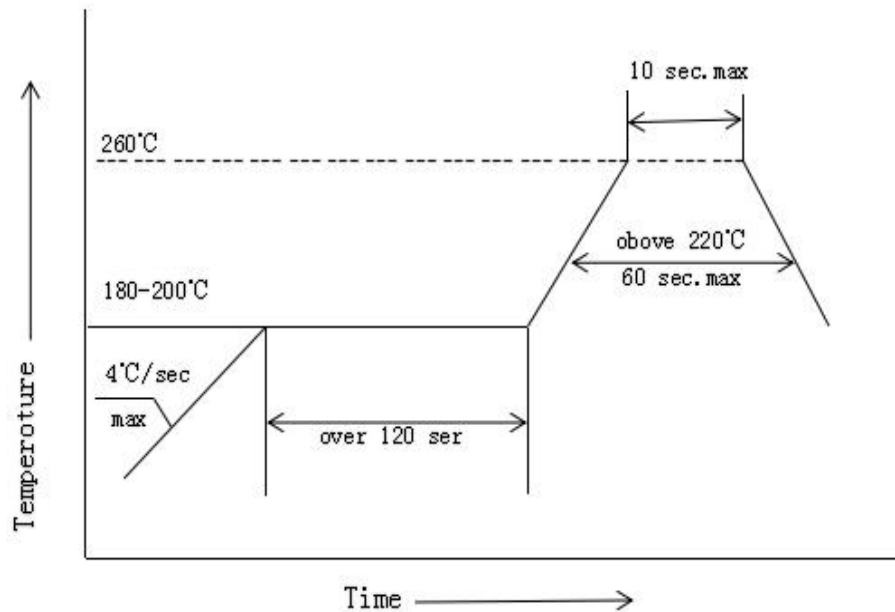

Soldering iron

- 1.When hand soldering, the temperature of the iron must less than 300°C for 3 seconds
- 2.The hand solder should be done only one times

Repairing

Repair should not be done after the LEDs have been soldered. When repairing is unavoidable, a double-head soldering iron should be used (as below figure). It should be confirmed beforehand whether the characteristics of LEDs will or will not be damaged by repairing.

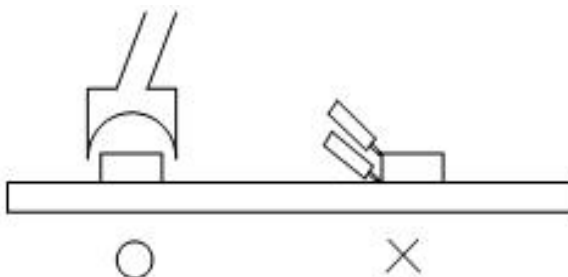

Storage

The package is sealed:

- 1.Recommended storage condition :At 5 °C~30°C and relative humidity 90% RH max.
- 2.It is recommended that SMD out of their original packaging are used within Three months.

The package is opened:

- 1.Completed within 24 hours.
- 2.Stored at5 °C~30°C and 60% RH or less.
- 3.LEDs stored more than 24 hours should be baked at about 65 °C±5 °C for at least 24 hours before solder assembly.

ESD

Static Electricity will damage the LED.

The following procedures may decrease the possibility of ESD damage.

- 1.All productive machinery and test instruments must be electrically grounded.
- 2.Use a conductive wrist band or anti-electostatic glove when handling these LEDs.
- 3.Manintain a humidity level of 50%RH or higher in production areas.
- 4.Use anti-static packaging for transport and storage.

Handling Precautions

- 1.Do not stack together assembled PCBs containing LEDs. Impact may scratch the silicone lens or damage.
- 2.Not available in the situation of acidity for PH.
- 3.Electrostatic sensitive device

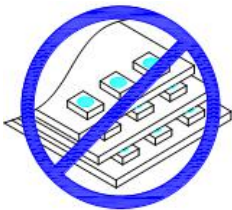

Packaging

Carrier tape (MPQ:4000PCS/reel)

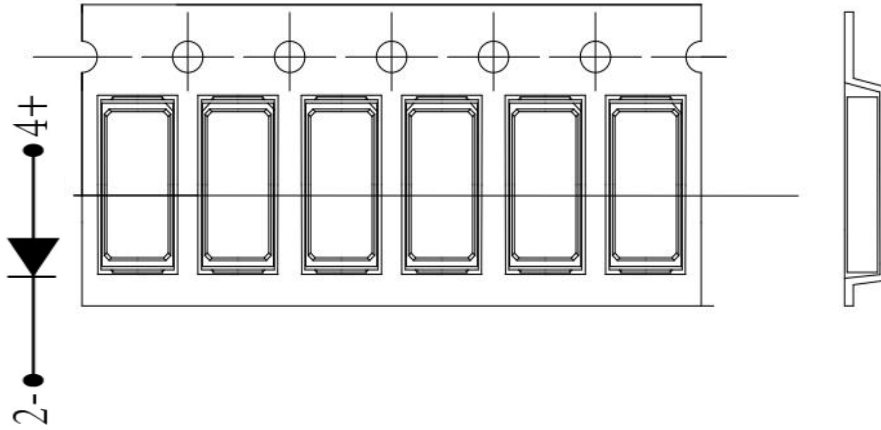

Note: The tolerances unless mentioned is ± 0.1 mm, Unit: mm

Moisture Resistant Packaging

