



Data Sheet

Customer: _____
Part No: CL-BIT1005DBW-10K-02
Sample No: _____
Description: 1005 SMD White Color
Item No: _____

Customer			
Check	Inspection	Approval	Date

Features

- _1.00mmX0.50mm SMT LED, 0.50mm THICKNESS.
- _LOW POWER CONSUMPTION.
- _WIDE VIEWING ANGLE.
- _IDEAL FOR BACKLIGHT AND INDICATOR.
- _VARIOUS COLORS AND LENS TYPES AVAILABLE.
- _PACKAGE: 4000 PCS / REEL.
- _RoHS COMPLIANT.

Description

The Yellow source color devices are made with
Gallium
Arsenide Phosphide on Gallium Phosphide
Yellow Light

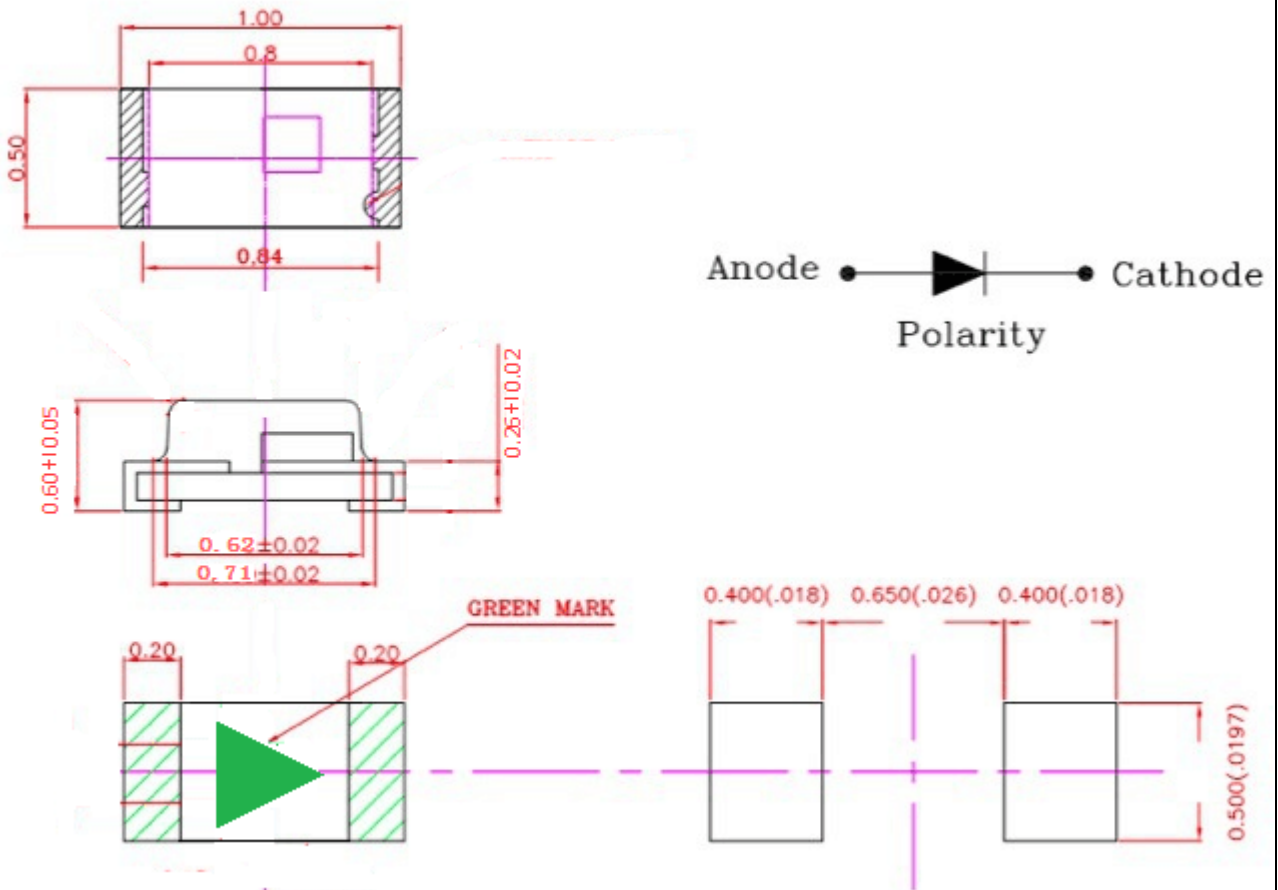
Package Dimensions

Notes:

1. All dimensions are in millimeters (inches).
2. Tolerance is ± 0.1 (0.004") unless otherwise noted.
3. Specifications are subject to change without notice.

Selection Guide

Part No.	Dice	Lens Type	Iv (mcd) @ 20mA		Viewing Angle
			Min.	MAX.	2 θ 1/2
CL-BIT1005DBW-10K-02	White (GaN)	Yellow Diffused	450	750	120

Note:

1. $\theta_{1/2}$ is the angle from optical centerline where the luminous intensity is 1/2 the optical centerline value.

Electrical / Optical Characteristics at T_A=25°C

Symbol	Parameter	Device	Typ.	Max.	Units	Test Conditions
λ_{peak}	Peak Wavelength	White	6600K	12500K	nm	IF=20mA
λ_D	Dominant Wavelength	White			nm	IF=20mA
$\Delta\lambda_{1/2}$	Spectral Line Half-width	White			nm	IF=20mA
C	Capacitance	White			pF	VF=0V;f=1MHz
VF	Forward Voltage	White	2.8	3.3	V	IF=20mA
IR	Reverse Current	White		2	uA	VR = 5V

Remarks:

If special sorting is required (e.g. binning based on forward voltage, luminous intensity, or wavelength), the typical accuracy of the sorting process is as follows:

1. Wavelength: +/-1nm
2. Luminous Intensity: +/-15%
3. Forward Voltage: +/-0.1V

Note: Accuracy may depend on the sorting parameters

Absolute Maximum Ratings at T_A=25°C

Parameter	White	Units
Power dissipation	135	mW
DC Forward Current	30	mA
Peak Forward Current [1]	140	mA
Reverse Voltage	5	V
Operating/Storage Temperature	-40°C To +85°C	

Note:

1. 1/10 Duty Cycle, 0.1ms Pulse Width.

BIN Code	Test Condition @20mA	
DBW	Vfmin(v)	Vfmax (v)
1	2.8	2.9
2	2.9	3.0
3	3.0	3.1
4	3.1	3.2
5	3.2	3.3

BIN Code	Test condition: @20mA	
DBW	IVmin(mcd)	IVmax (mcd)
1	450	550
2	550	650
3	650	750

Color area distribution

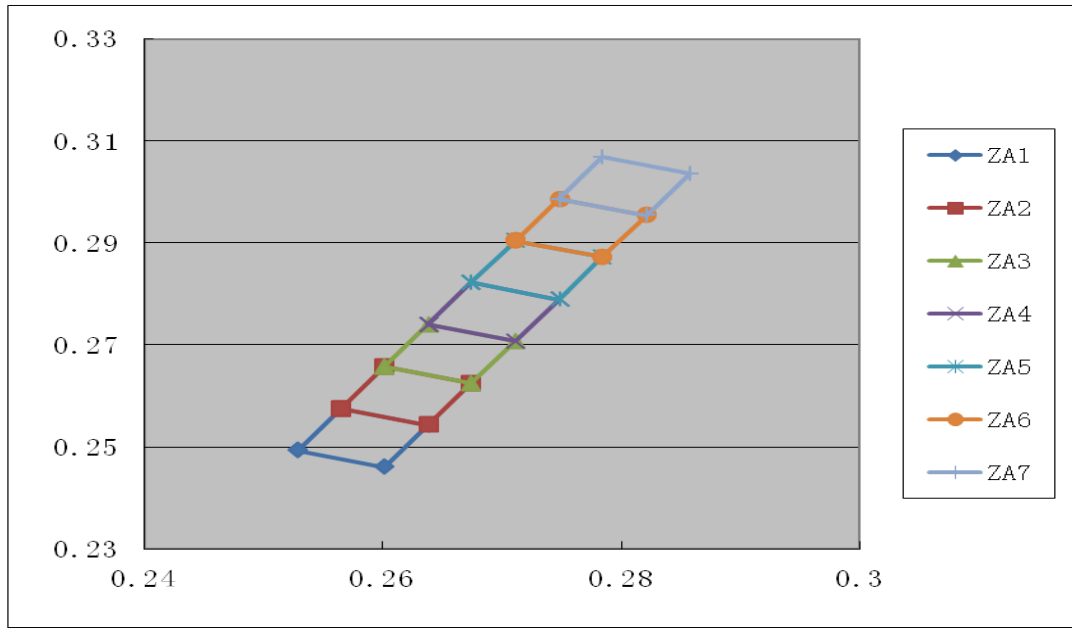

ZA1	0.2528	0.2493	0.2565	0.2575	0.2638	0.2543	0.2601	0.246	0.2528	0.2493
ZA2	0.2565	0.2575	0.2601	0.2657	0.2674	0.2625	0.2638	0.2543	0.2565	0.2575
ZA3	0.2601	0.2657	0.2638	0.274	0.2711	0.2707	0.2674	0.2625	0.2601	0.2657
ZA4	0.2638	0.274	0.2674	0.2822	0.2748	0.2789	0.2711	0.2707	0.2638	0.274
ZA5	0.2674	0.2822	0.2711	0.2904	0.2784	0.2872	0.2748	0.2789	0.2674	0.2822
ZA6	0.2711	0.2904	0.2748	0.2986	0.2821	0.2954	0.2784	0.2872	0.2711	0.2904
ZA7	0.2748	0.2986	0.2784	0.3069	0.2857	0.3036	0.2821	0.2954	0.2748	0.2986

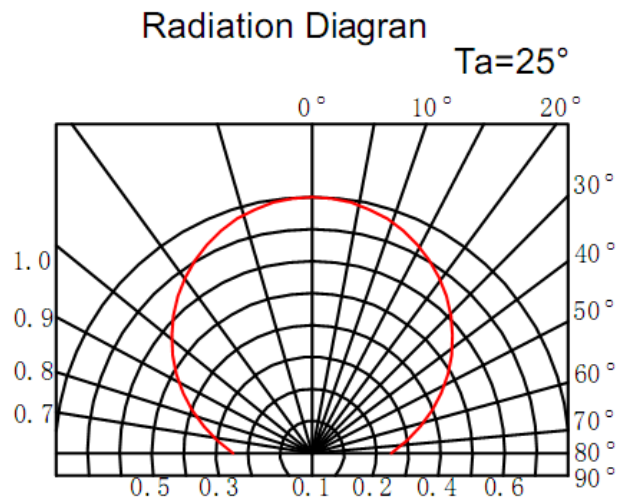
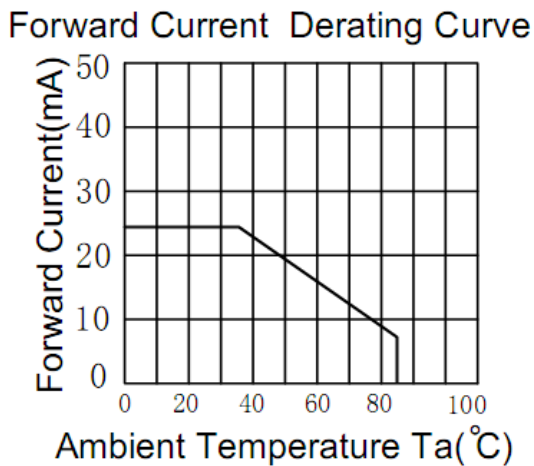
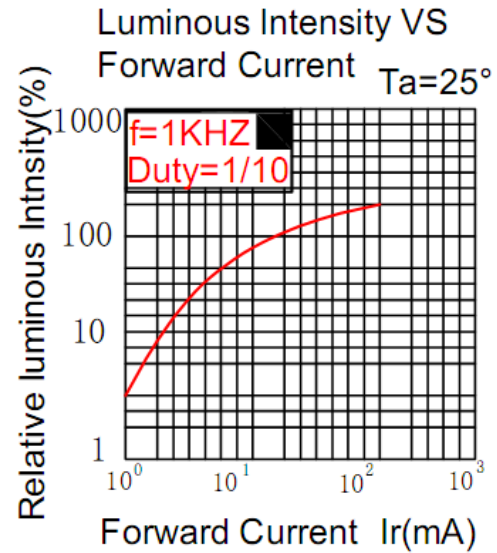
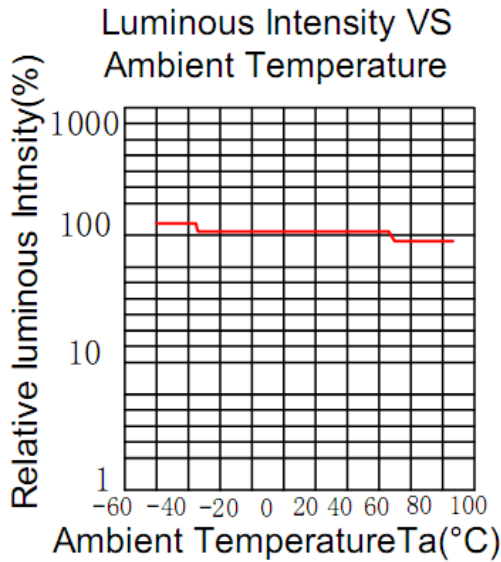
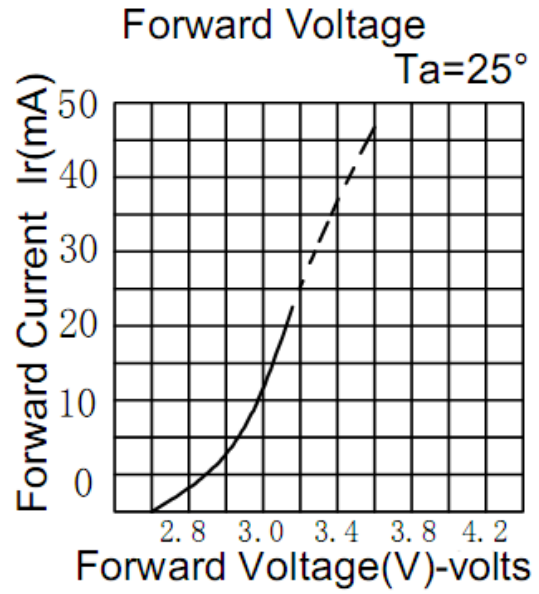
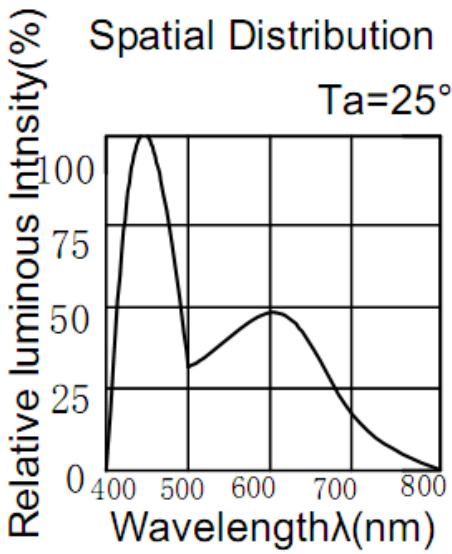

RELIABILITY

Test Items and Results

NO	Test item	Standard	Test Conditions	Hours/ Cycles	Sample	Number of Damaged
1	Temperature Cycle	JEITA ED-4701	-40°C ~ 25°C ~ 100°C ~ 25°C 30min 5min 30min 5min	100 Cycles	50	0/50
2	Thermal Shock	MIL-STD-2 02G	-40°C ~ 100°C 15 min 15 min	500 Cycles	50	0/50
3	High Temperature Storage	JEITA ED-4701 200 201	T _a =100°C	1000 hours	50	0/50
4	Low Temperature Storage	JEITA ED-4701 200 201	T _a =-40°C	1000 hours	50	0/50
5	Life Test		T _a =25±5°C I _r =20mA	1000 hours	50	0/50
6	High Humidity Heat Life Test		T _a =60°C RH=85% I _r =20mA	1000 hours	50	0/50
7	Solderabilit y (reflow soldering)	JEITA ED-4701 300 303	T _{sol} =235°C±5°C,5 sec Use flux	Weld once, 5 seconds	10	0/10
8	Solder resistance (reflow soldering)	JEITA ED-4701 300 301	T _{sol} =260°C,10 sec Pretreatment: 35°C 95%RH 96 hours	Weld twice, 10 seconds each time	10	0/10

If the above test items are different from the customer's test requirements or have special customer requirements, they can be trial-produced according to the actual situation and in accordance with the customer's requirements. If the customer does not require it, the trial-production should be carried out according to our company's test standards. Different products use different currents for testing.

5. Cautions

(1) Soldering Conditions

Number of reflow process shall be less than 2 times and cooling process to normal temperature is required between first and Second soldering process.

(Recommended soldering conditions)

回流焊接 Reflow Soldering		手工焊接	
预热温度 Pre-heat	有铅 Lead Solder	无铅 Lead-free Solder	温度 Temperature
预热时间 Pre-heat time	140 ~ 160° C	180 ~ 200° C	焊接时间 Soldering time
峰值温度 Peak temperature	120 sec. Max.	120 sec. Max.	350° C Max.
焊接时间 Soldering time	230° C Max.	240° C Max.	3 sec. Max.
条件 Condition	10 sec. Max.	10 sec. Max.	(one time only)
	参考下图	参考下图	

(Lead Solder)

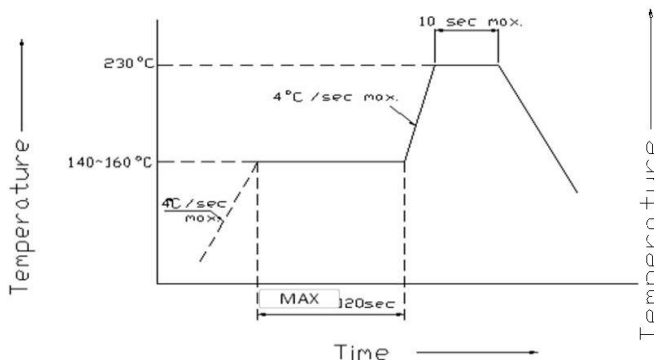

(Lead-Free Solder)

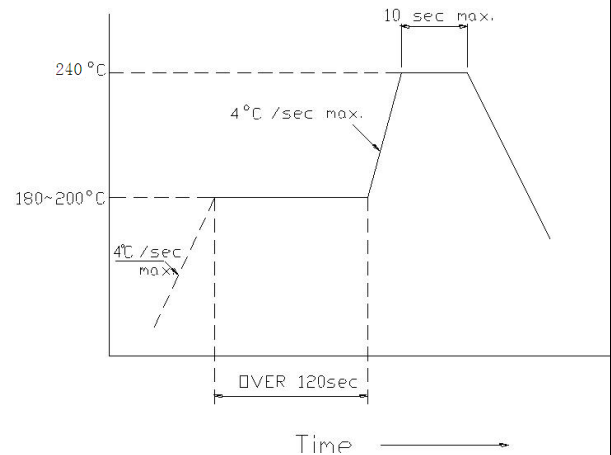

(2) Static Electricity

It is recommended that a wrist band or an anti-electrostatic glove be used when handling the LEDs.

All devices, equipment and machinery must be properly grounded.

Damaged LEDs will show some unusual characteristics such as the forward voltage becomes lower, or the LEDs do not light at the low current. Criteria : (VF > 2.0V at IF=0.5mA)

(3) Moisture Proof Package

It is recommended that moisture proof package be used .

(4)Cautions:

4.1.

Please check if there is air leak before opening the package, if so, please return the goods back to take drying process for later using.

4.2

Products can be used within 15days after packaging, after that, they must be:

4.2.

Soldered within 24 hrs

4.2.2

Used in the condition: 30°C within and 60%RH below

4.2.3

Stored in 30%RH for moisture below.

4.3.

Products cannot be used for and over 15days after being packaged unless opening the package and take drying our process in 85°C/6H.

4.4.

Products not be used for or over 60days after being packaged please return back to take drying out and packaging process for forward using.

4.5.

Products not be used after opening the package need to be dried out for 85°C/6H

PACKAGING

The LEDs are packed in cardboard boxes after taping

包装方式:

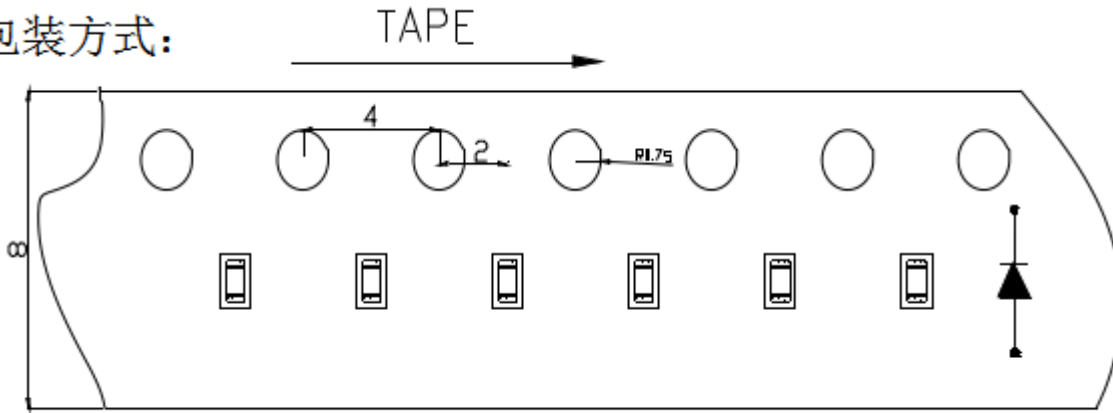

Package: 4000PCS/reel

Reel Dimensions

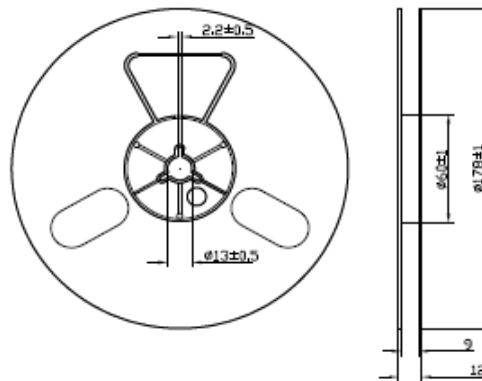

Moisture Resistant Packaging

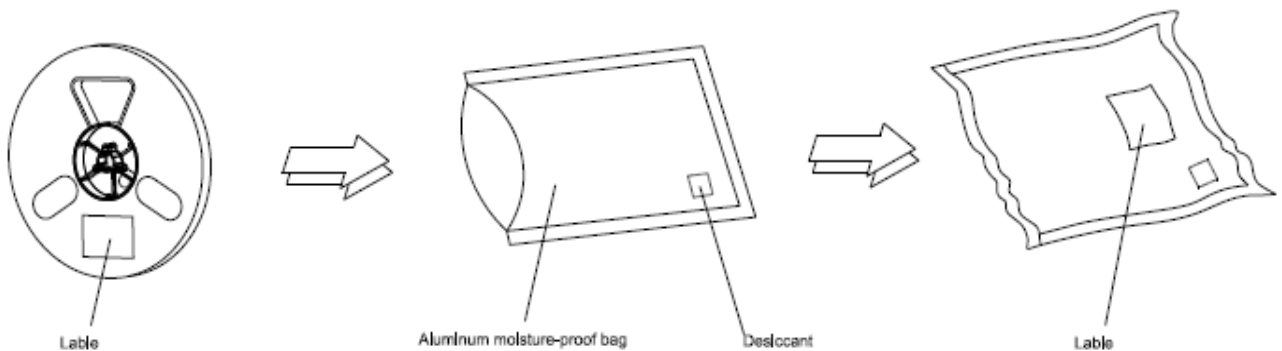

Note: The tolerances unless mentioned is ± 0.1 mm, Unit: mm