

# Data Sheet

---

Customer: \_\_\_\_\_

Part No: CL-5019RGYC1C-CA-01

Sample No: \_\_\_\_\_

Description: 5mm Round Red/Green/Yellow LED

Item No: \_\_\_\_\_

Customer			
Check	Inspection	Approval	Date

**Features:**

- . Choice of various viewing angles
- . Available on tape and reel.
- . Reliable and robust
- . Pb free
- .The product itself will remain within RoHS compliant version.

**Technical Data Sheet**

This product is generally used as indicator and luminary for electronic equipment such as household appliance, communication equipment, and dashboard.

**Applications**

- TV set
- Monitor
- Telephone
- Computer

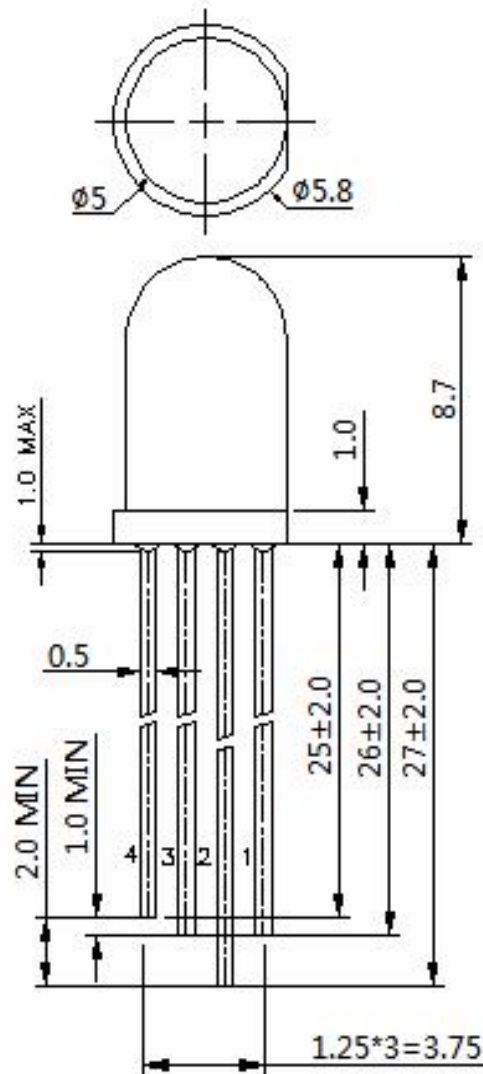
**Package Dimensions:**

**NOTES**

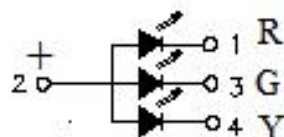
- 1.All dimensions are in millimeters .
- 2.Tolerance is  $\pm 0.25\text{mm}$  unless otherwise noted.



**Selection Guide**

Part No.	Dice	Lens Type	Luminous intensity(mcd) @ 20mA			Viewing Angle
			Min	Typ	Max	2θ1/2
CL-5019RGYC1C-CA-01	(R)AlGaInP	Water Clear	800	1700	--	20
	(G)InGaN		5000	8000	--	
	(Y)AlGaInP		1300	2000	--	

Note:

1.1/2 is the angle from optical centerline where the luminous intensity is 1/2 the optical centerline value.

2.the above luminous intensity measurement allowance tolerance ±15%

**Electrical / Optical Characteristics at Ta=25°C**

Parameter	Device	Min.	Typ.	Max.	Units	test conditions
Forward Voltage	R	1.8	2.0	2.4	V	IF=20mA
	G	2.8	3.0	3.6		
	Y	1.8	2.0	2.4		
Reverse Current	IR	--	--	10	uA	VR = 5V
Dominate Wavelength	R	618	--	630	nm	IF=20mA
	G	510	--	520		
	Y	585	--	595		
Half Wavewidth	R	--	20	--	nm	IF=20mA
	G	--	30	--		
	Y	--	15	--		

**Absolute Maximum Ratings at Ta=25°C**

Parameter	Symbol	Rating	Units
Power Dissipation	R	60	mW
	G	90	
	Y	60	
DC Forward Current	IF	30	mA
Peak Forward Current [1]	IFP	60	
Reverse Voltage	VR	5	V
Electrostatic Discharge (HBM)	ESD	2000	V
Operating Temperature	Topr	-20~+85	°C
Storage Temperature	Tstg	-40~+100	
Lead Soldering Temperature [1.6mm(.063") From Body]		260°C for 5 seconds	

Note:

1. 1/10 Dut cycle,0.1ms pulse width.

2. Measurement Errors:Forward Voltage:±0.1V,Luminous Intensity:±10% mcd,Wavelength(x,y)±1nm/±0.01

Typical optical characteristics curves

Ambient Temperature VS. Forward Current

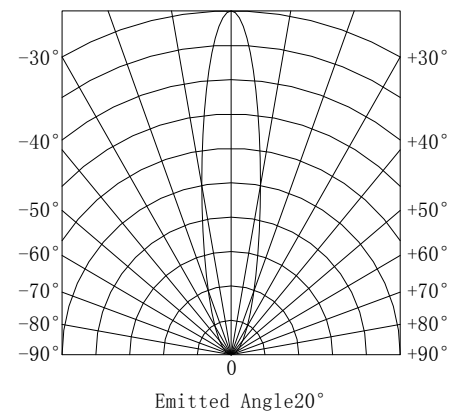
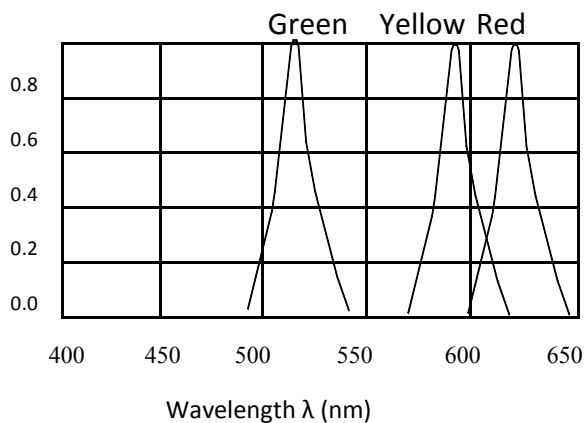
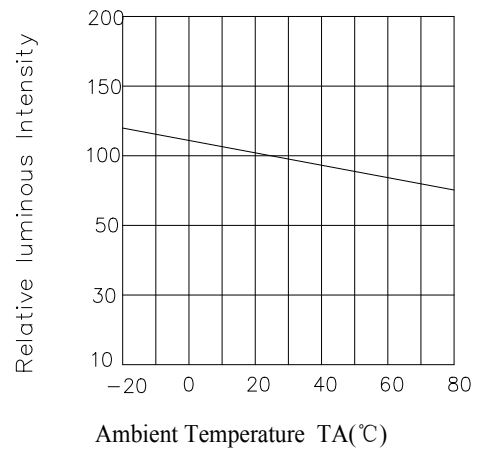
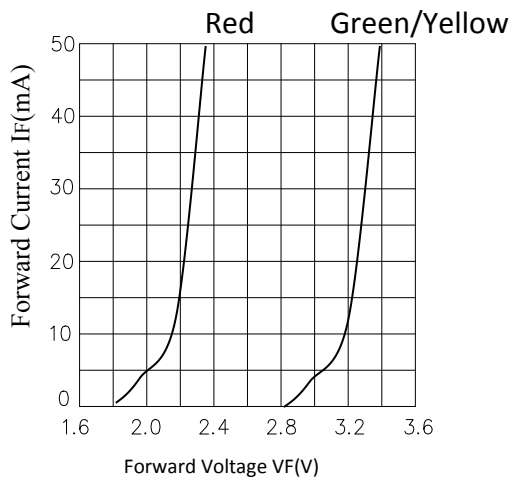
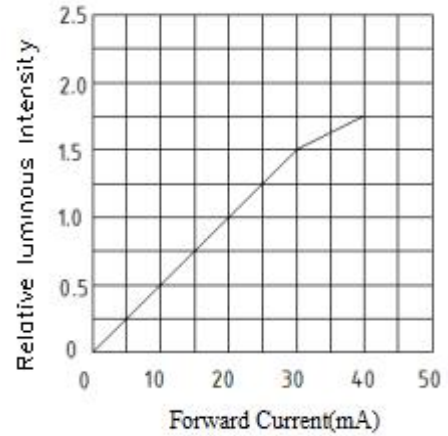
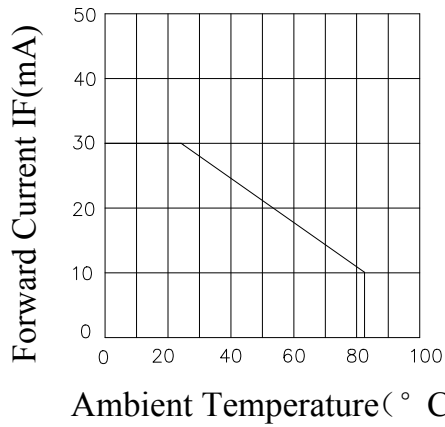

**Reliability Test Item And Condition**

Test Item	Test Condition	Ref.Standard	Time	Quantity	Ac/Re
Life Test	Ta=25°C±5°C IF=20mA	JESD22-A108	1000H	22Pcs	0/1
Temperature cycle	100°C±5°C 30 min. ↑↓5 min -40°C±5°C 30 min.	JEITA ED-4701 100 105	100 Cycles	22Pcs	0/1
High Temperature Storage	Ta=100±5°C	JEITA ED-4701 200 201	1000H	22Pcs	0/1
Low Temperature Storage	Ta=-40±5°C	JEITA ED-4701 200 202	1000H	22Pcs	0/1
Storage at High Temperature/High Humidity	Ta:85±5°C ,RH:85±5%	JEITA ED-4701 100 103	1000H	22Pcs	0/1
Soldering resistance	Tsol=260±5°C 10s	JEITA ED-4701 300 302	1 times	22Pcs	0/1
Solderability	Tsol=235±5°C 5s	JEITA ED-4701 300 303	1 times	22Pcs	0/1

**Criteria For Judging Damage**

Test Items	Symbol	Test conditions	Criteria For Judgement	
			Min.	Max.
Forward Voltage	VF	IF=20mA		U.S.L*)x1.1
Reverse Current	IR	VR = 5V		U.S.L*)x2.0
Luminous intensity	IV	IF=20mA	L.S.L*)x0.7	

U.S.L: Upper standard level      L.S.L: Lower standard level

The technical information shown in the data sheets are limited to the typical characteristics and circuit examples of the referenced products. It does not constitute the warranting of industrial property nor the granting of any license.

**1.Storage time**

LED can be stored for a year under the condition:the temperature of 5°C-28°C and humility of RH60%,These production must be re-inspected and tested before use if their storage time exceed a year.

**2.ESD countermeasure**

Static electricity and high volt can damage LED, must put on static glove and static fillet,  
Soldering tool and the cover of device must connect the ground,  
soldering condition follows the related stating of production specification manual.

**3.Soldering**

When soldering leave a minimum of 2mm clearance from the base of the lens to the soldering point.  
Dipping the lens into the solder must be avoided.  
Do not apply any external stress to the lead frame during soldering while the LED is at high temperature.  
Recommended soldering conditions:

Soldering iron		Wave soldering	
Temperature	320°C Max	Pre-heat Pre-heat time	120°C Max 120 sec.Max
Soldering time	3 sec.Max (one time only)	Solder wave Soldering time	260°C Max 5 sec.Max

Note: Excessive soldering temperature and/or time might result in deformation of the LED lens or catastrophic failure of the LED.

**4.Drive Method**

An LED is a current-operated device,In order to ensure intenity uniformity on multiple LEDs connected in parallel in an application,it is recommended that a current limiting resistor be incorporated in the drive circuit,in series with each LED as shown in Circuit A below.

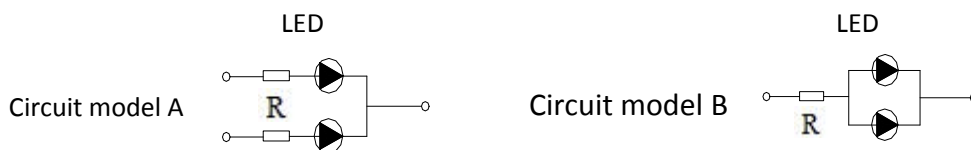

(A)Recommended circuit

(B)The brightness of each LED might appear different due to the differences in the I-V characteristics of those LEDs.

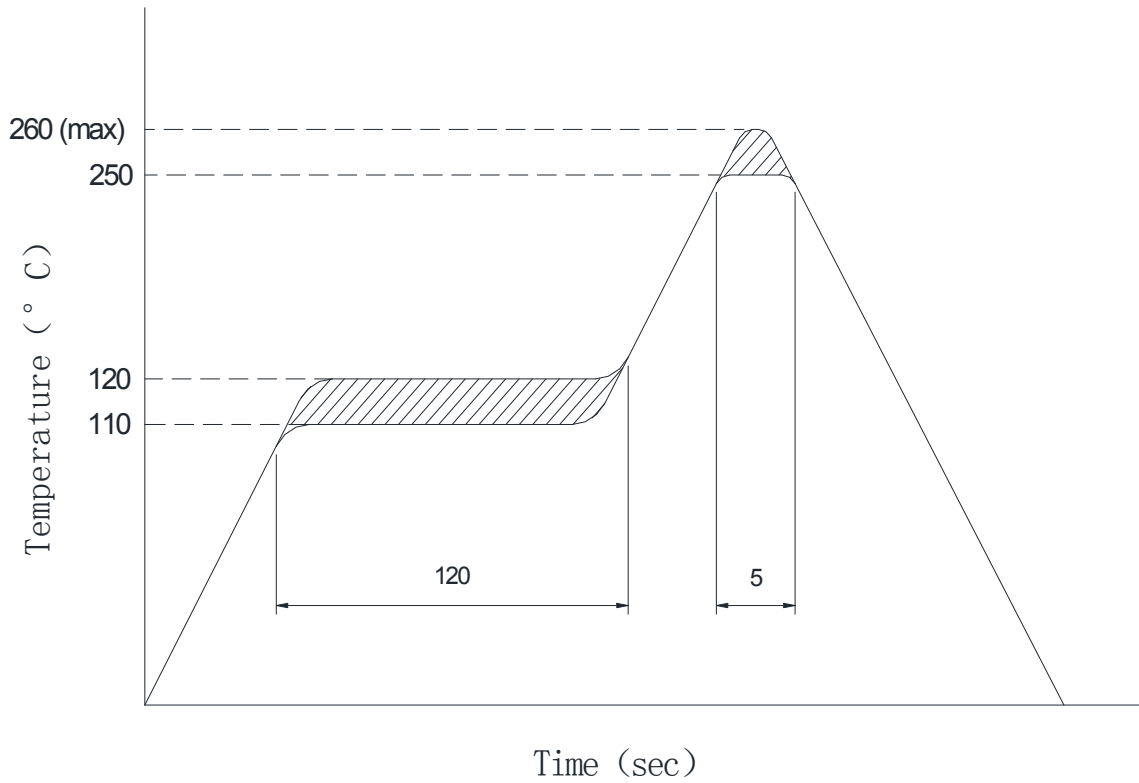
**Soldering temperature curve chart**

**NOTES**

- After soldering the LEDs, the epoxy bulb should be protected from mechanical shock or vibration until the LEDs return to room temperature.
- A rapid-rate process is not recommended for cooling the LEDs down from the peak temperature.