

Features

- Low Power Consumption
- High Efficiency
- Round Type
- T1 (10mm) Diameter
- With Flange
- Solder Leads Without Stand-off
- Compliant With RoHS

Descriptions

- Chip Material: AlGaInP/GaAs
- Emitting Color: Ultra Orange
- Lens Color: Water Clear

ATTENTION



OBSERVE PRECAUTIONS
FOR HANDLING
ELECTROSTATIC
SENSITIVE DEVICES

Outline Drawing

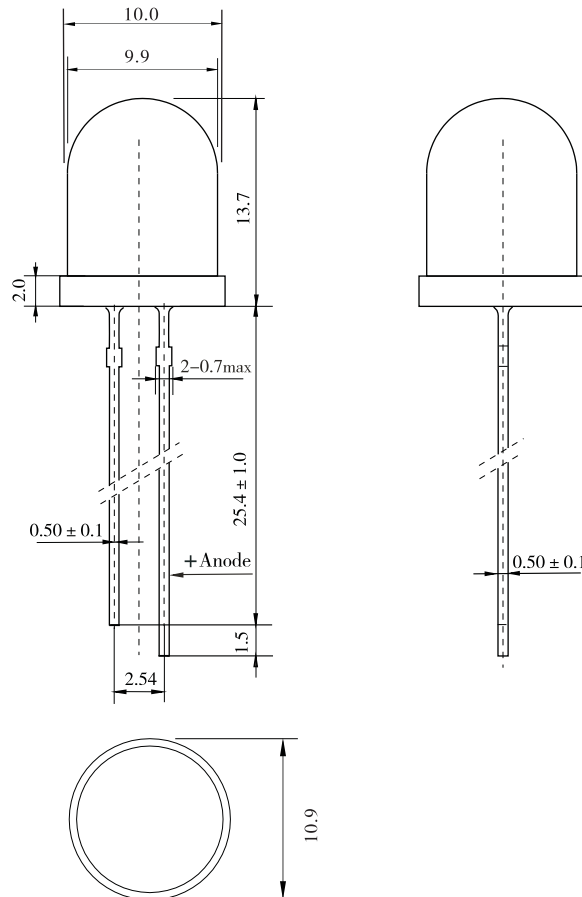

Tolerance is $\pm 0.25\text{mm}$ unless otherwise noted, Unit=mm
Pin bending $\leq \text{length} * 1\%$

Electrical Optical Characteristics (Ta=25°C)

| Parameter | Symbol | Ultra Orang | | | Unit | Test Condition |
|--------------------------|------------------|-------------|------|-----|---------|----------------|
| | | Min | Typ | Max | | |
| Forward Voltage | V_F | --- | 2.0 | 2.4 | V | IF=20mA |
| Luminous Intensity | I_V | 2610 | 3750 | --- | mcd | IF=20mA |
| Peak Wavelength | λ_P | --- | 632 | --- | nm | IF=20mA |
| Dominant Wavelength | λ_d | --- | 624 | --- | nm | IF=20mA |
| Spectral Line half-width | $\Delta \lambda$ | --- | 20 | --- | nm | IF=20mA |
| Reverse Leakage Current | I_R | --- | --- | 50 | μA | VR=5V |
| Viewing Angle | $2\theta_{1/2}$ | --- | 20 | --- | Deg | IF=20mA |

Absolute Maximum Parameters (Ta=25°C)

| Parameter | Symbol | Condition | Rating | Unit |
|-----------------------------|--------|----------------|------------|--------|
| Power Dissipation | P_D | --- | 80 | mW |
| Reverse Voltage | V_R | --- | 5 | V |
| Forward Average Current | I_F | --- | 30 | mA |
| Temperature Coefficient | I/C | --- | 0.33 | mA/ °C |
| Pulse Current | IFP | Duty=1/10,1kHz | 100 | mA |
| Operating Temperature Range | Topr | --- | -25 ~ +85 | °C |
| Storage Temperature Range | Tstg | --- | -30 ~ +100 | °C |
| Soldering Condition | Tsd | --- | 260°C/5sec | °C |

NOTE:

Luminous Intensity Measurement allowance is $\pm 10\%$.

$2\theta_{1/2}$ is the off-axis angle at which the luminous intensity is half the axial luminous intensity.

The dominant wavelength is derived from the CIE chromaticity diagram and represents the single wavelength which defines the color of the device.

Typical Electro/Optical Characteristic Curves (Ta=25°C)

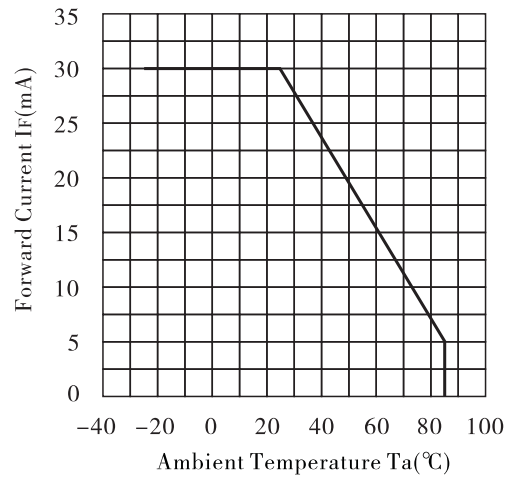
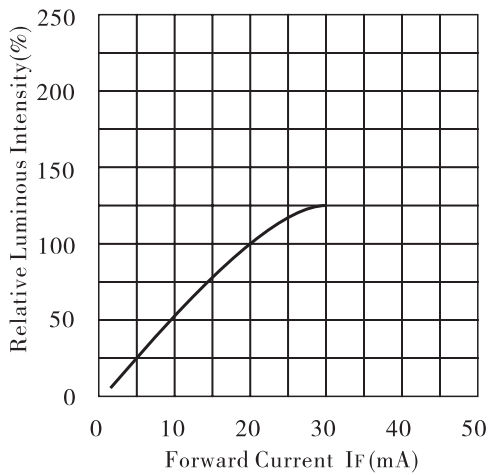
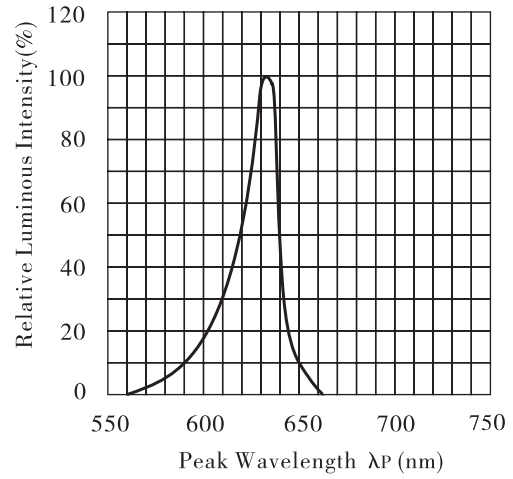
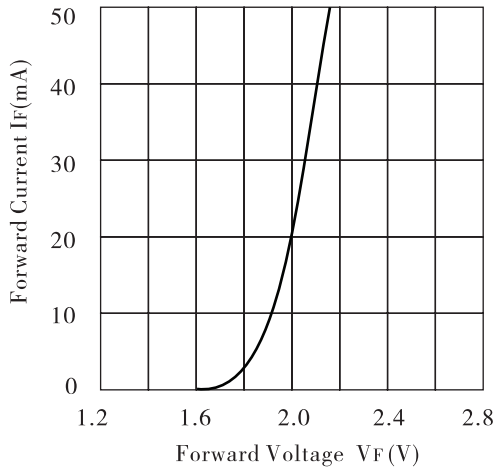

Directive Characteristics

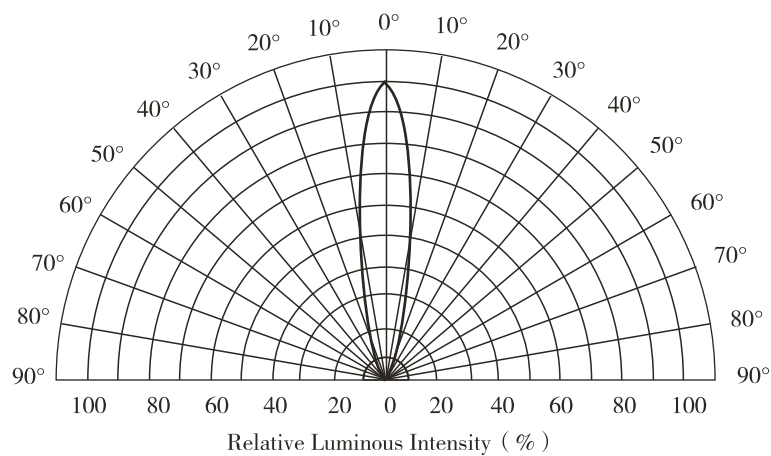

Reliability Test Conditions

| Test Item | Test Condition | Result | Judgment Criteria |
|---|--|--------|---|
| Consecutive operating life test | IF=20mA, T=25℃, t=168h | 0/100 | Forward Voltage $V_F(V) = \text{Upper Limit} \times 1.2$ Reverse Leakage Current $I_R(\mu A) = \text{Upper Limit} \times 2.0$ Luminous Intensity IV (mcd) = Lower Limit $\times 0.7$ |
| High temperature storage life test | T=100℃, t=168h | 0/100 | |
| Low temperature storage life test | T=25℃, t=168h | 0/100 | |
| High temperature humidity storage life test | T=85 ± 2℃, RH=85% ± 3, t=168h | 0/100 | |
| Temperature cycle test | -25℃~25℃~100℃ 30min 5min 30min 10cycles | 0/100 | |
| Thermal shock test | 100℃ 0℃ 5min 5min 20cycles | 0/100 | |
| Soldering heat test | T=260 ± 5℃, t=10s ± 1s | 0/100 | |
| Solderability test | T=235 ± 5℃, t=5s ± 0.5s | 0/100 | Steeped Part ≥ 95% |
| Fall test | h=100cm, 50times | 0/100 | Surface Appearance Photoelectric Properties Intact |
| Terminal strength test | W=9.8N, t=30 ± 5s | 0/100 | |
| Lead bending test | W=4.9N, 2times | 0/100 | |

Package

| Item | Inner packaging bag | Inner packaging box |
|----------|---------------------------------|---|
| Material | Antistatic bag | Single corrugated box |
| Quantity | 400PCS | Single corrugated box × 5 =2000PCS |
| Marking | Label Marking: Type、Quantity | Certificate of conformity Marking: Product name 、 Type、Quantitye 、 Date of manufacture |
| Size | 16×23(cm) | 30×19×11.5(cm) |