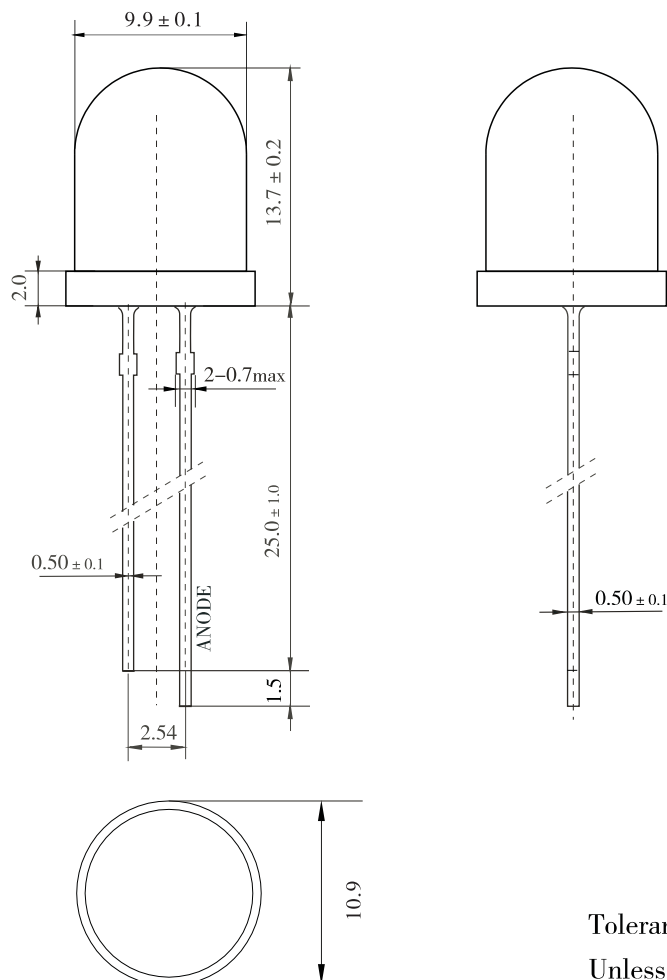

FEATURES

Low power consumption.
 High Efficiency
 Round type
 T1 (3mm) diameter
 With Flange
 Solder leads without stand-off
 Compliant with RoHS

DESCRIPTIONS

Chip Material: AlGaInP/GaAs
 Emitting Color: Red
 Lens Color: Red Diffused

OUTLINE DRAWING

ATTENTION

OBSERVE PRECAUTIONS
 FOR HANDLING
 ELECTROSTATIC
 SENSITIVE DEVICES

Tolerance is ± 0.25 mm
 Unless Otherwise Specified.

ELECTRICAL OPTICAL CHARACTERISTICS (Ta=25°C)

Parameter	Symbol	Min	Typ	Max	Unit	Test Condition
Forward Voltage	V_F	-	2.0	2.3	V	IF=20mA
Luminous Intensity	I_v	102	160	-	mcd	IF=20mA
Peak Wavelength	λ_p		660		nm	IF=20mA
Spectral Line half-width	$\Delta \lambda$		15		nm	IF=20mA
Reverse Leakage Current	I_R			50	μA	VR=5V
Viewing Angle	$2 \theta_{1/2}$		30		Deg	IF=20mA

ABSOLUTE MAXIMUM PARAMETERS (Ta=25°C)

Parameter	Symbol	Condition	Rating	Unit
Power Dissipation	P_D	---	80	mW
Reverse Voltage	V_R	IR=50 μA	5	V
Forward Average Current	I_F	---	30	mA
Temperature coefficient	I/C	---	0.4	mA/ °C
Pulse Current	IFP	Duty=1/10,1kHz	100	mA
Operating Temperature Range	Topr	---	-25 ~ +85	°C
Storage Temperature Range	Tstg	---	-40 ~ +100	°C
Soldering Condition	Tsd	---	265°C/5sec	°C

NOTE:

Luminous Intensity Measurement allowance is $\pm 10\%$.

$2 \theta_{1/2}$ is the off-axis angle at which the luminous intensity is half the axial luminous intensity.

The dominant wavelength is derived from the CIE chromaticity diagram and represents the single wavelength which defines the color of the device.

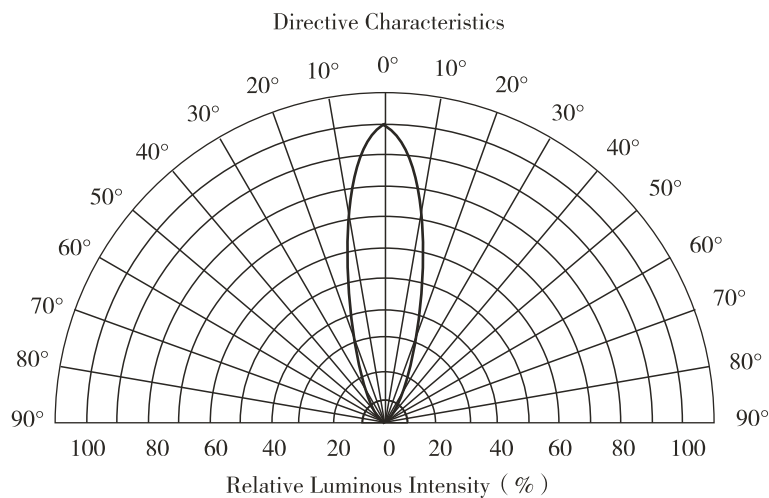
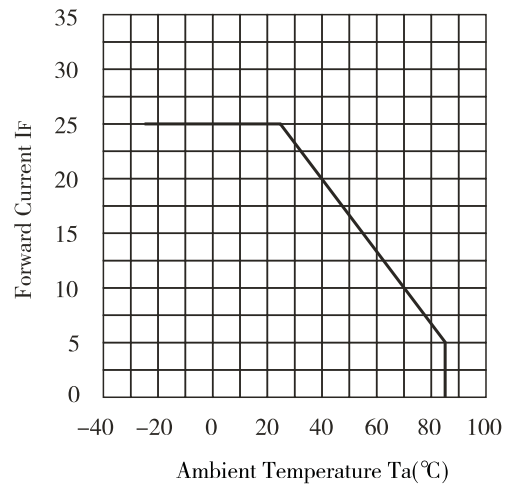
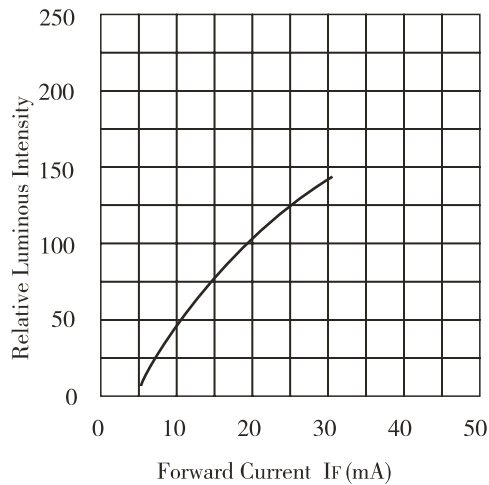
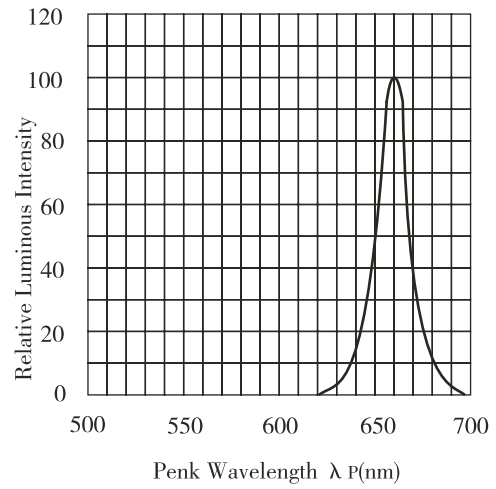
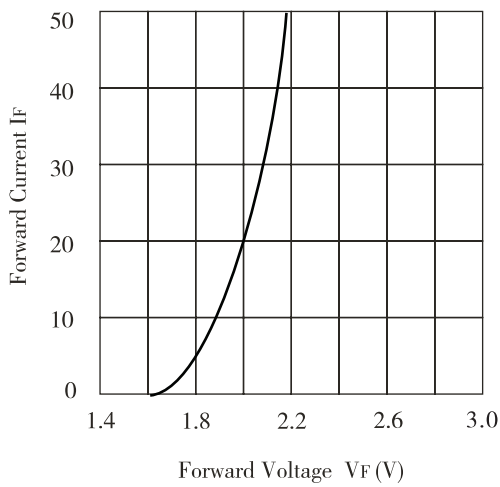
TYPICAL ELECTRO-OPTICAL CHARACTERISTIC CURVES (Ta=25°C)

Luminous Intensity Ranks(IF=20mA Ta=25°C)

Bin Code	Min(mcd)	Max(mcd)
L	102	145
M	145	200
N	200	280
P	280	390

Package

Item	Inner packaging bag	Inner packaging box	Outside packaging box
Material	Antistatic bag	Single corrugated box	Double corrugated box
Quantity	250 PCS	Single corrugated box × 8 =2000 PCS	Inner packaging box × 4 =8000PCS
Marking	Label Marking: Type、Quantity	Certificate of conformity Marking: Product name 、 Type、Quantitye、 Date of manufacture	Packing list Marking: Product name 、 Type、Quantitye、 Date of shipment
Size	16×23(cm)	28.7×18.2×14.4(cm)	38.5×30.5×31.5(cm)