



## Data Sheet

---

Customer: \_\_\_\_\_

Part No: \_\_\_\_\_

CLT-2832AUR-11

Sample No: \_\_\_\_\_

Description: \_\_\_\_\_

0.28 inch 3 Digit Red Color

Item No: \_\_\_\_\_

Customer			
Check	Inspection	Approval	Date

**Descriptions**

1. Emitting Color: Ultra Red
2. Lens Color: White Diffused
3. Surface Black Color : Black
4. Dice Material: AlGaInP/GaAs

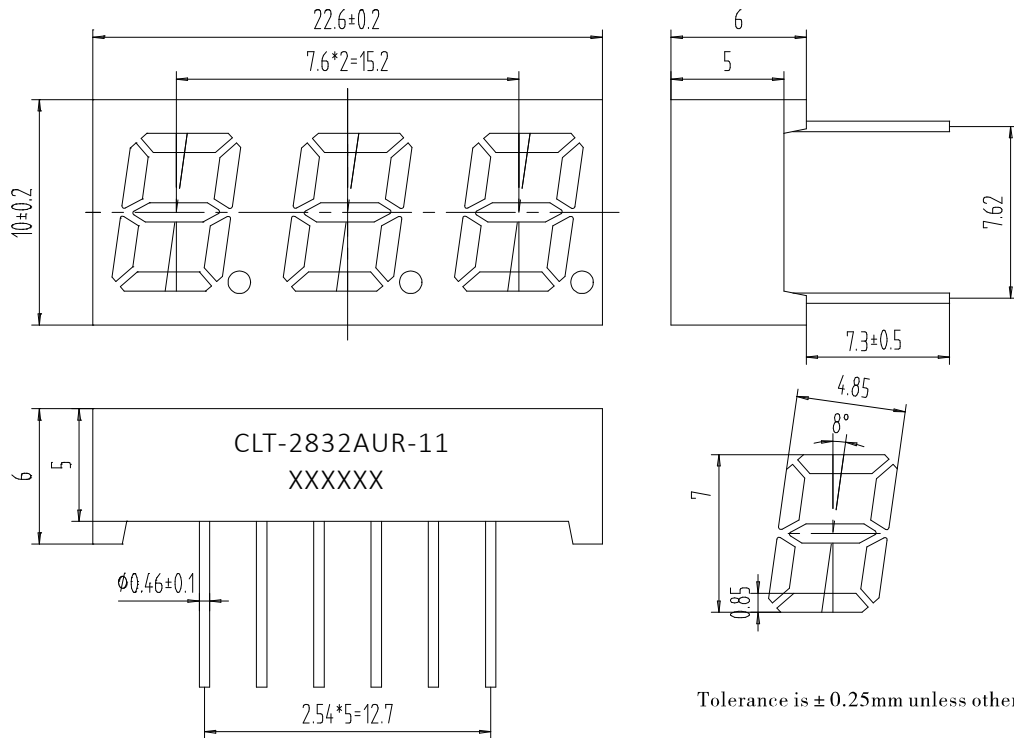
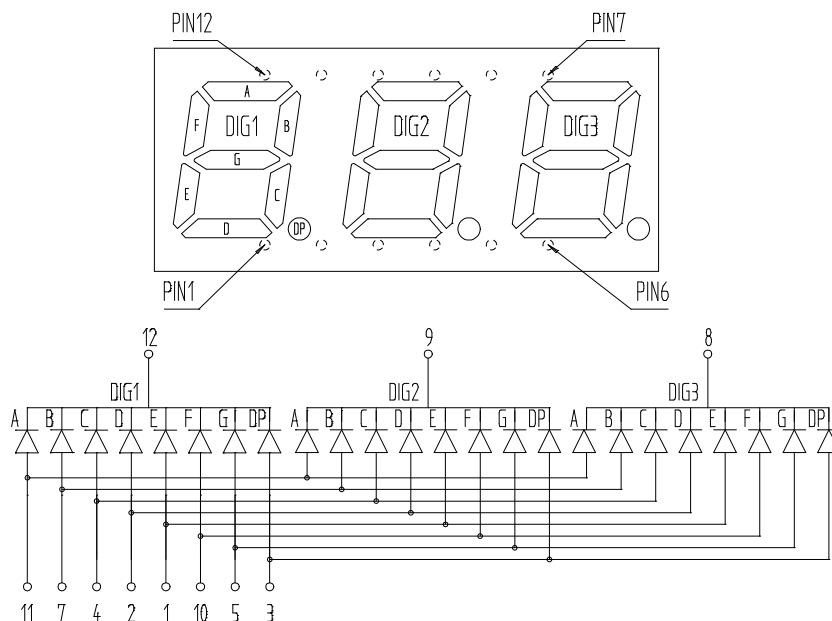
**Outline drawing**

**Internal Circuit Diagram (C.A.)**

## Electrical optical characteristics ( Ta=25°C )

Parameter	Symbol	Ultra Red			Unit	Test Condition
		Min	Typ	Max		
Forward Voltage	$V_F$	---	2.0	2.4	V	IF=20mA
Luminous Intensity	$I_V$	7.0	13.7	---	mcd	IF=10mA
Peak Wavelength	$\lambda_P$	---	645	---	nm	IF=20mA
Dominant Wavelength	$\lambda_d$	---	635	---	nm	IF=20mA
Spectral Line half-width	$\Delta\lambda$	---	20	---	nm	IF=20mA
Reverse Leakage Current	$I_R$	---	---	50	$\mu A$	VR=5V

## Absolute Maximum Parameters(Ta=25°C)

Parameter	Symbol	Condition	Rating	Unit
Power Dissipation	$P_D$	---	80	mW
Reverse Voltage	$V_R$	---	5	V
Forward Average Current	$I_F$	---	30	mA
Temperature Coefficient	I/C	---	0.33	mA/°C
Pulse Current	IFP	Duty=1/10,1kHz	100	mA
Operating Temperature Range	Topr	---	-25 ~ +85	°C
Storage Temperature Range	Tstg	---	-30 ~ +100	°C
Soldering Condition	Tsd	---	260°C/5sec	°C

Typical Electro–Optical characteristic curves (  $T_a=25^\circ\text{C}$  )

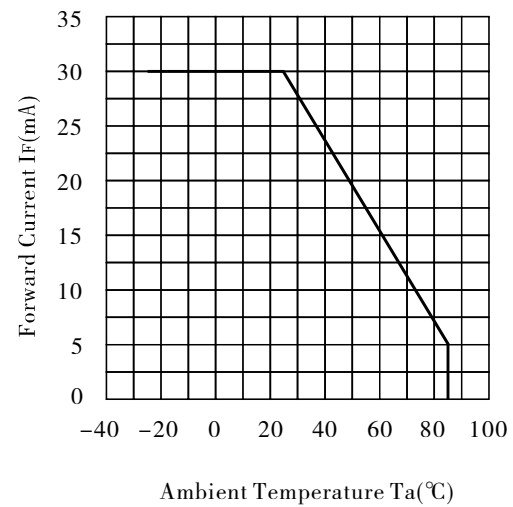
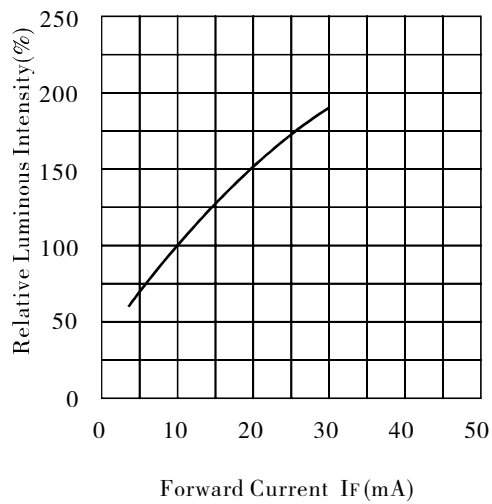
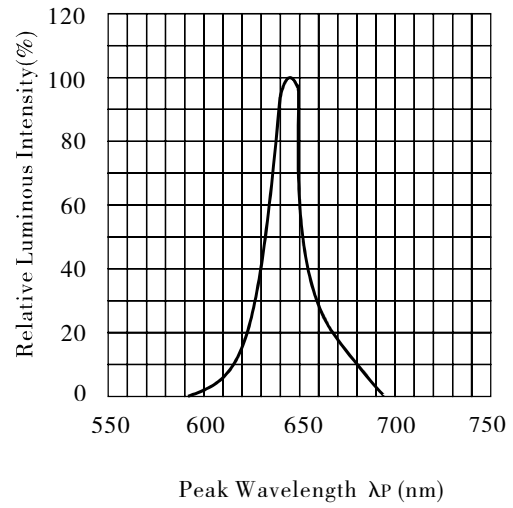
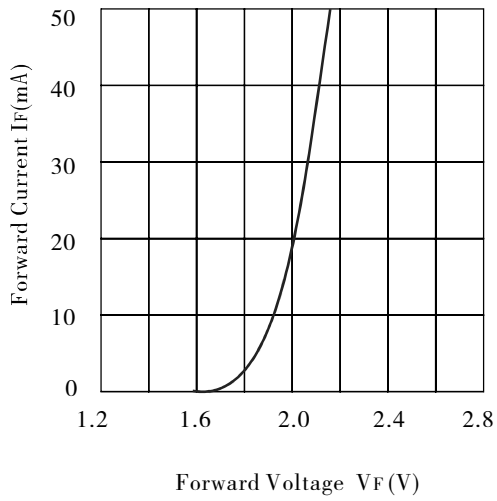

## Reliability test conditions

Test Item	Test Condition	Result	Judgment criteria
Consecutive operating life test	IF=20mA, T=25°C, t=168h	0/12	Forward Voltage $V_F(V) = \text{Upper Limit} \times 1.2$ Reverse Leakage Current $I_R(\mu A) = \text{Upper Limit} \times 2.0$ Luminous Intensity $I_v$ (mcd) = Lower Limit $\times 0.7$
High temperature storage life test	T=100°C, t=168h	0/12	
Low temperature storage life test	T=-25°C, t=168h	0/12	
high Temperature humidity storage life test	T=85 ± 2°C, RH=85% ± 3, t=168h	0/12	
Temperature cycle test	-25°C~25°C~100°C, 30min 5min 30min 10cycles	0/12	
Thermal shock test	100°C 0°C 5min 5min 20 cycles	0/12	
Soldering heat test	T=260 ± 5°C, t=10s ± 1s	0/12	
Solderability test	T=230 ± 5°C, t=5s ± 0.5s	0/12	Steeped Part ≥ 95%
Fall test	h=100cm, Free fall, 3times	0/12	Intact
Terminal strength test	W=9.8N, t=30 ± 5s	0/12	
Lead Bending test	W=4.9N, 2times	0/12	