



## Data Sheet

---

Customer: \_\_\_\_\_  
Part No: CLD-3621AUR-11  
Sample No: \_\_\_\_\_  
Description: 0.36 inch 2 Digit Red Color  
Item No: \_\_\_\_\_

| Customer |            |          |      |
|----------|------------|----------|------|
| Check    | Inspection | Approval | Date |
|          |            |          |      |

Descriptions

1. Emitting color: Ultra Red
2. Lens color: White Diffuse
3. Surface black color : Black
4. Dice material: AlGaInP

Outline drawing

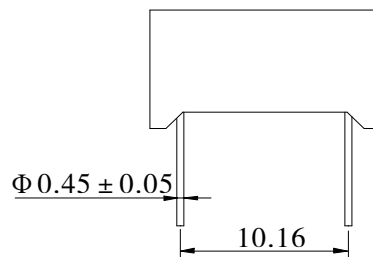
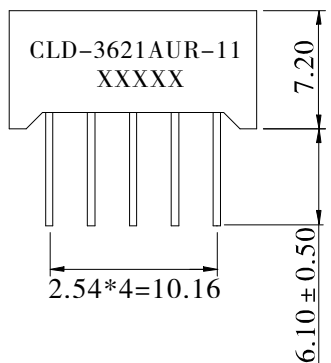
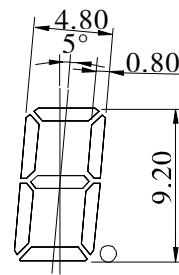
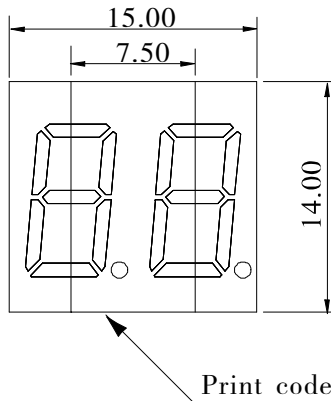

Tolerance is ± 0.25mm unless otherwise noted  
PIN Bending ≤ Length \* 1%

Internal Circuit Diagram (C.C.)

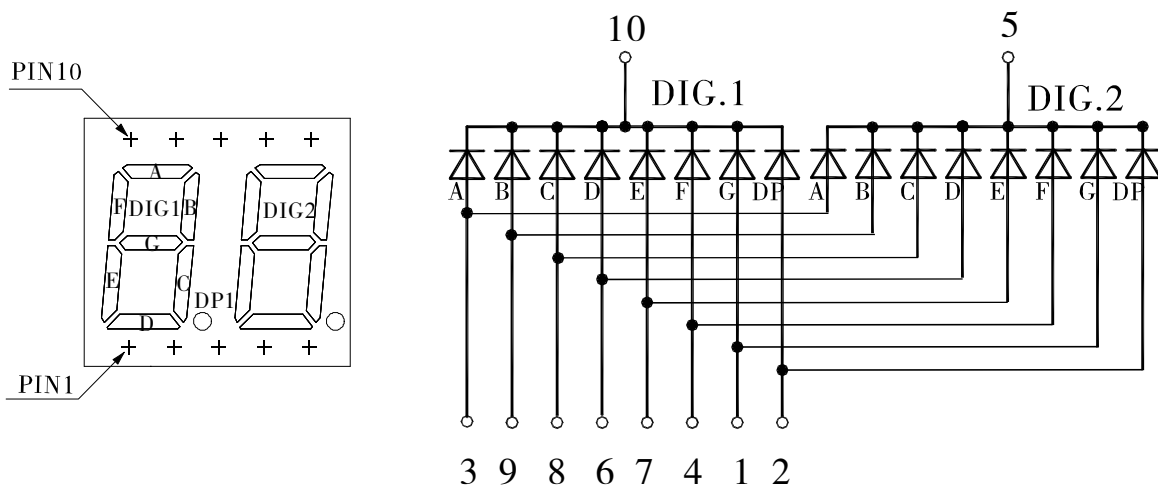

**Electrical optical characteristics ( Ta=25°C )**

| Parameter                | Symbol         | Ultra Red |     |     | Unit | Test Condition     |
|--------------------------|----------------|-----------|-----|-----|------|--------------------|
|                          |                | Min       | Typ | Max |      |                    |
| Forward Voltage          | V <sub>F</sub> | ---       | 2.0 | 2.2 | V    | IF=20mA            |
| Luminous Intensity       | I <sub>V</sub> | 2.8       | 4.0 | --- | mcd  | IF=20mA            |
| Peak Wavelength          | λ <sub>P</sub> | ---       | 645 | --- | nm   | IF=20mA            |
| Dominant Wavelength      | λ <sub>d</sub> | ---       | 639 | --- | nm   | IF=20mA            |
| Spectral Line half-width | Δλ             | ---       | 20  | --- | nm   | IF=20mA            |
| Reverse Leakage Current  | I <sub>R</sub> | ---       | --- | 50  | μA   | V <sub>R</sub> =5V |

**Absolute maximum parameters ( Ta=25°C )**

| Parameter                   | Symbol | Condition      | Rating     | Unit  |
|-----------------------------|--------|----------------|------------|-------|
| Power Dissipation           | PD     | ---            | 80         | mW    |
| Reverse Voltage             | VR     | ---            | 5          | V     |
| Forward Average Current     | IF     | ---            | 30         | mA    |
| Temperature coefficient     | I/C    | ---            | 0.33       | mA/°C |
| Pulse Current               | IFP    | Duty=1/10,1kHz | 100        | mA    |
| Operating Temperature Range | Topr   | ---            | -25 ~ +85  | °C    |
| Storage Temperature Range   | Tstg   | ---            | -30 ~ +100 | °C    |
| Soldering Condition         | Tsd    | ---            | 260/5sec   | °C    |

Typical Electro-Optical characteristic curves ( Ta=25°C )

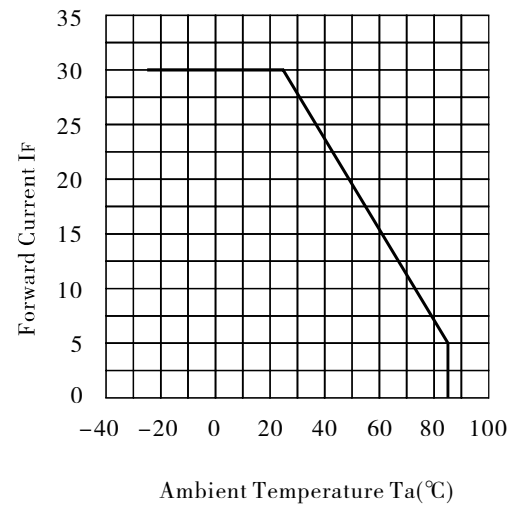
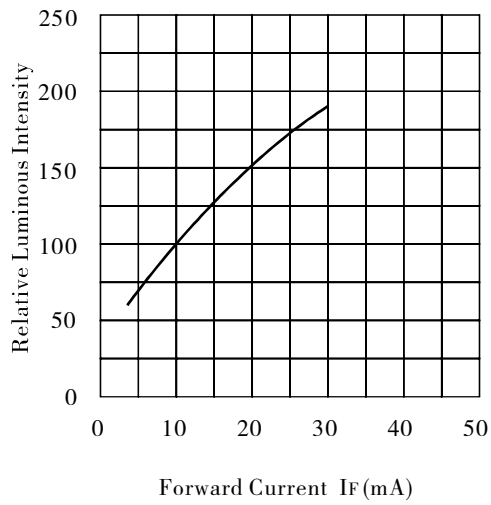
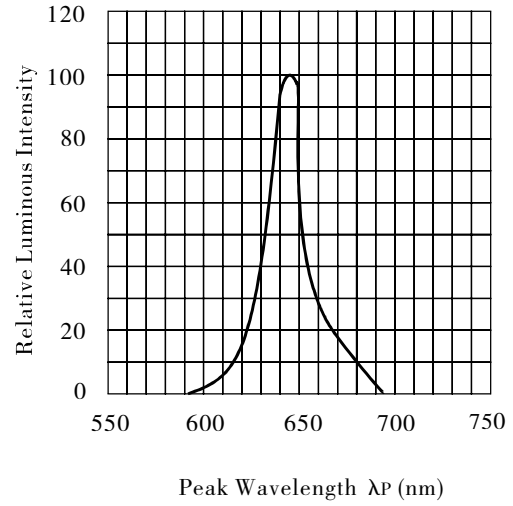
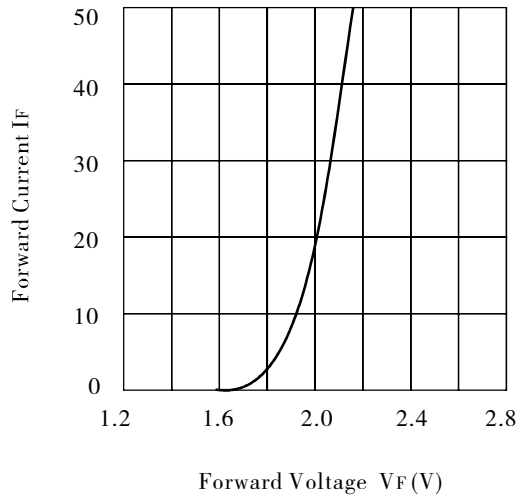

**Reliability test conditions**

| Test Item                                   | Test Condition                                 | Result | Judgment criteria  |
|---|--|--------|--|
| Consecutive operating life test             | IF=20mA, T=25°C, t=168h                        | 0/12   | Forward Voltage<br>$V_F(V) = \text{Upper Limit} \times 1.2$<br>Reverse Leakage Current<br>$I_R(\mu A) = \text{Upper Limit} \times 2.0$<br>Luminous Intensity $I_v$<br>(mcd) = Lower Limit $\times 0.7$ |
| High temperature storage life test          | T=100°C, t=168h                                | 0/12   |  |
| Low temperature storage life test           | T=-25°C, t=168h                                | 0/12   |  |
| high Temperature humidity storage life test | T=85 ± 2°C, RH=85% ± 3, t=168h                 | 0/12   |  |
| Temperature cycle test                      | -25°C~25°C~100°C,<br>30min 5min 30min 10cycles | 0/12   |  |
| Thermal shock test                          | 100°C 0°C<br>5min 5min 20 cycles               | 0/12   |  |
| Soldering heat test                         | T=260 ± 5°C, t=10s ± 1s                        | 0/12   |  |
| Solderability test                          | T=230 ± 5°C, t=5s ± 0.5s                       | 0/12   | Steeped Part ≥ 95%   |
| Fall test                                   | h=100cm, Free fall, 3times                     | 0/12   | Intact   |
| Terminal strength test                      | W=9.8N, t=30 ± 5s                              | 0/12   |  |
| Lead Bending test                           | W=4.9N, 2times                                 | 0/12   |  |