



GAIA TECH
ABS2-ABS10



1.0A SURFACE MOUNT GLASS PASSIVATED BRIDGE RECTIFIER

Features

- Glass Passivated Die Construction
- Low Forward Voltage Drop
- High Current Capability
- High Surge Current Capability
- Designed for Surface Mount Application
- Plastic Material-UL Flammability 94V-0

Mechanical Data

- Case:SOPA-4, Mold Plastic
- Terminals:Plated Leads Solderable per MIL-STD-202, Method208
- Polarity:As Marked on Case
- Mounting Position:Any
- Marking:Type Number

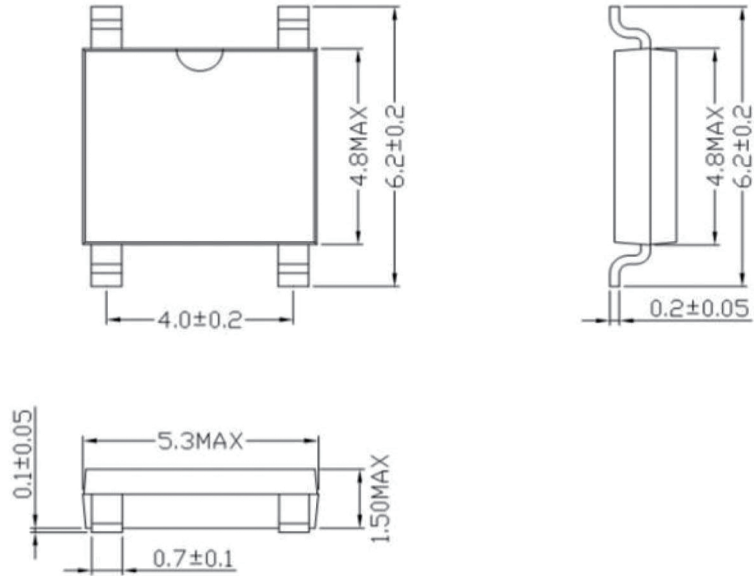

Maximum Ratings and Electrical Characteristics @TA=25°C unless otherwise specified

Single Phase, half wave, 60Hz, resistive or inductive load. For capacitive load, derate current by 20%.

Parameter	Symbol	ABS2	ABS4	ABS6	ABS8	ABS10	UNIT
Maximum repetitive peak reverse voltage	V_{RRM}	200	400	600	800	1000	V
Maximum RMS voltage	V_{RMS}	140	280	420	560	800	V
Maximum DC blocking voltage	V_{DC}	200	400	600	800	1000	V
Maximum Average forward output rectified current on glass-epoxy P.C.B on aluminum substrate	I (AV)	0.8 1.0					V
Peak forward surge current 8.3ms single sine-wave superimposed on rated load(JEDEC Method)	IFSM	30					A
Maximum instantaneous forward voltage @0.4A drop per diode @1.0A	VF	1.0 1.1					V
Maximum DC reverse current at TA=25°C rated DC blocking voltage per leg TA=125°C	IR	5.0 500					uA
Typical thermal resistance per leg (Note 1)	R θ JA R θ JL	80 25					°C/W
Operating junction temperature range	TJ	-55 to +150					°C
storage temperature range	Tstg	-55 to +150					°C

Note:

1. Mounted on glass epoxy PC board with 1.3mm² solder pad.
2. Mounted on aluminum substrate PC board with 1.3mm² solder pad.
3. Measured at 1.0MHz and applied reverse of 4.0V D.C.



GAIA TECH

ABS2-ABS10



1.0A SURFACE MOUNT GLASS PASSIVATED BRIDGE RECTIFIER

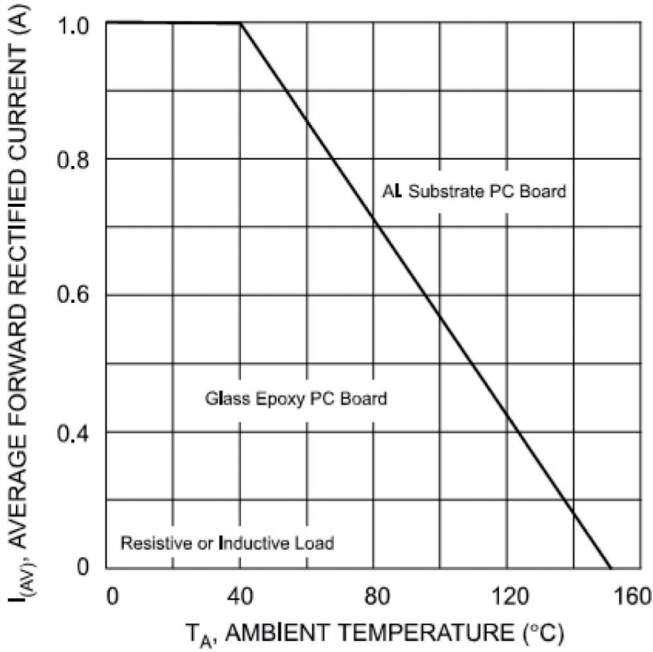

Fig. 1 Output Current Derating Curve

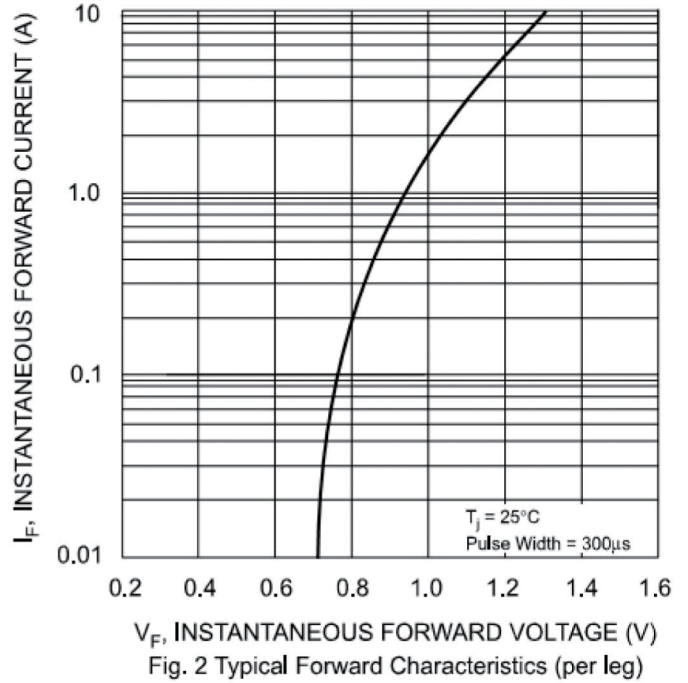

Fig. 2 Typical Forward Characteristics (per leg)

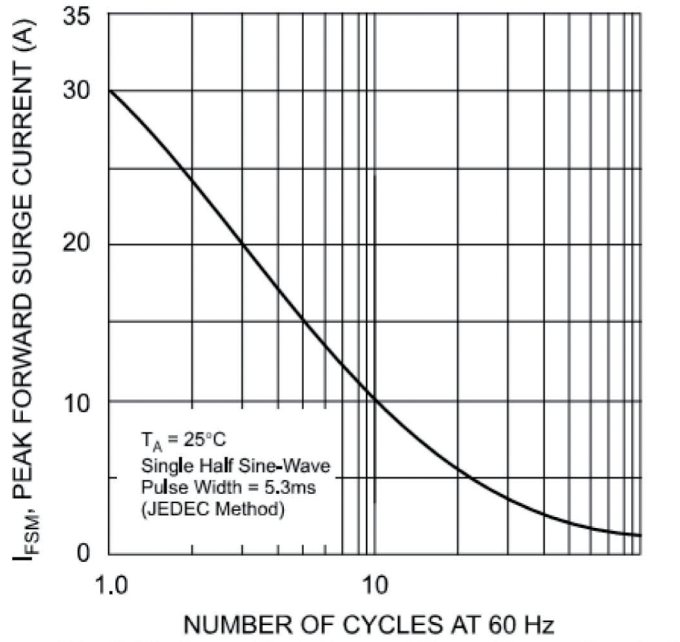

Fig. 3 Maximum Peak Forward Surge Current (per leg)

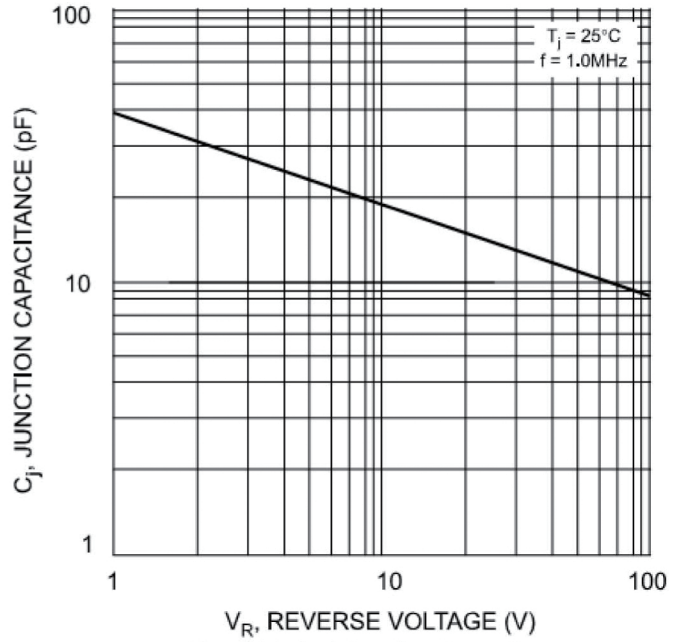

Fig. 4 Typical Junction Capacitance