



GAIA TECH

SOD-123 Plastic-Encapsulate Diodes

BAV16W/1N4148W FAST SWITCHING DIODES

FEATURES

- Fast Switching Speed
- Surface Mount Package Ideally Suited for Automatic Insertion
- For General Purpose Switching Applications
- High Conductance

MARKING: T6,T4

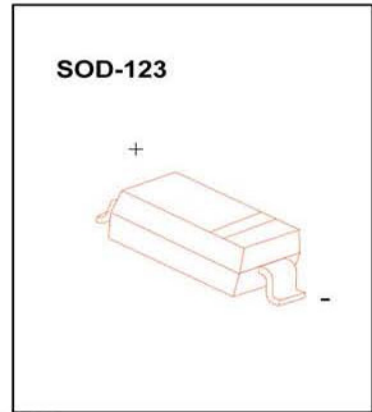

Maximum Ratings and Electrical Characteristics, Single Diode @T_a=25°C

Parameter	Symbol	Limits	Unit
Non-Repetitive Peak reverse voltage	V _{RM}	100	V
Peak Repetitive Peak reverse voltage	V _{RRM}	100	V
Working Peak Reverse Voltage	V _{RWM}		
DC Blocking Voltage	V _R		
RMS Reverse Voltage	V _{R(RMS)}	71	V
Forward Continuous Current	I _{FM}	300	mA
Average Rectified Output Current	I _O	150	mA
Peak forward surge current @=1.0μs	I _{FSM}	2.0	A
@=1.0s		1.0	
Power Dissipation	P _d	500	mW
Thermal Resistance from Junction to Ambient	R _{θJA}	250	°C/W
Junction temperature	T _J	150	°C
Storage temperature	T _{STG}	-65~+150	°C

Electrical Ratings @T_a=25°C

Parameter	Symbol	Min.	Typ.	Max.	Unit	Conditions
Forward voltage	V _{F1}			0.715	V	I _F =1mA
	V _{F2}			0.855	V	I _F =10mA
	V _{F3}			1.0	V	I _F =50mA
	V _{F4}			1.25	V	I _F =150mA
Reverse current	I _{R1}			1	μA	V _R =75V
	I _{R2}			25	nA	V _R =20V
Capacitance between terminals	C _T			2	pF	V _R =0V, f=1MHz
Reverse Recovery Time	t _{rr}			4	ns	I _F =I _R =10mA I _{rr} =0.1X I _R , R _L =100Ω



GAIA TECH

Typical Characteristics

BAV16W/1N4148W

