



Industrial



COTS



Test



COMM



The 4" x 2.4" footprint, high efficiency PFH500A series of AC-DC power modules are used in environments where convection or forced air cooling is not viable. Suitable for use in applications requiring a nominal 400 Hz input frequency, these pcb mounted power modules accept an 85 to 135 Vac input and deliver an adjustable, regulated 28V output. High ambient temperatures can be tolerated as the conduction cooled baseplate can withstand -40 to 100°C temperatures. These third generation modules also have a PMBus™ interface with read/write capability for remote monitoring and programming.

Features	Benefits
• Compact 4" x 2.4" x 0.53" Brick Package	• Less Board Area Required
• Metal Case	• Easier Thermal Management and Lower Radiated EMI
• 115 Vac 400 Hz input	• Suitable for Ground Based Aviation Support Use
• 100°C Rated Baseplate Temperature	• Cold plate / Conduction Cooling for Fanless and Rugged Environments
• PMBus™ Interface	• Remote Monitoring and Programming via i²C
• Optional Droop Mode Load Sharing	• Simplified Paralleling for Higher Power or Redundant Applications

Model Selector						
Model	Nominal Output Voltage (V)	Output Adjust Range (V)	Maximum Output Current (A)	Maximum Power (W) <sup>(1)</sup>	Mounting Inserts	Droop Mode Current Share
<a href="#">PFH500A-28-000-R</a>	28	22.4 - 33.6	18	504	3.3mm Ø Non-threaded	No
<a href="#">PFH500A-28-100-R</a>	28	22.4 - 33.6	18	504	3mm (M3) Threaded	No

<b>PFH500A</b>	-	<b>28</b>	-	<b>1</b>	<b>00</b>	-	<b>R</b>
		Output voltage 28V		0 Non-threaded inserts 1 M3 threaded inserts			RoHS Compliant

Related Products		
	Part Number	Description
Heatsink	<a href="#">HS00110</a>	2.4" x 4" x 1.5" aluminum heatsink with cylindrical pin fins with integrated thermal pad
EMI Common Mode Choke	<a href="#">ARA00499</a>	6.3 mH Common Mode Inductor, Through Hole
Evaluation Kits		Contact Technical Support

# Last Time Buy April 30, 2026

Specifications		
Model	PFH500A-28	
<b>Input</b>		
Input Voltage Range	Vac	85 - 135 (See derating curve)
Input Frequency	Hz	375 - 420
Input Current (115 Vac)	A	5.4
Inrush Current	A	10
Leakage Current	-	Will depend on the value of the external Y capacitors (refer to evaluation data)
Power Factor (80% load)	-	≥ 0.9
No Load Power Consumption	-	See evaluation report on website
Hold-up Time	ms	Will depend on the value of the external bulk capacitance (refer to evaluation data)
Efficiency (typ 115/230Vac, 100% Load)	%	90 / 92
Insulation Class	-	Class II
Safety Certifications and Markings	-	CE Mark and UKCA Mark
<b>Output</b>		
Output Voltage Setpoint Tolerance	%	±2% (115Vac, I <sub>o</sub> = 0%)
Line Regulation (50% Load)	%	0.15
Load Regulation (115/230Vac)	%	0.1
Droop Rate (-xDx-R suffix)	mV/A	50
Ripple & Noise	mV	400
Minimum Load	-	No minimum load required
Overcurrent Protection (hiccup)	A	21.5
Overvoltage Protection (max)	V	35.5
Overtemperature Protection	°C	Input line / output load dependent (Refer to <a href="#">Instruction Manual</a> )
Remote Sense	-	Yes
Remote ON/OFF	-	Negative Logic; Low (< 1V) = Module On (300 μA, 3.3V max)
Power Good	-	Active Low (< 1 Vdc @ 150 mA, 50V max)
Auxiliary Output	Vdc	10 - 14 @ 200 mA max.
External Load Capacitance (CC Mode)	uF	470 - 6,000
External Load Capacitance (CR Mode)	uF	470 - 20,000
Series Operation	-	Yes
Parallel Operation	-	Contact Technical Support
<b>Environmental</b>		
Operating Baseplate Temperature	°C	-40 - 100 (see derating curves)
Storage Temperature	°C	-55 to 125
Humidity (non condensing)	%RH	20-95 (Operating) / 10-95 (Non Operating)
Cooling	-	Conduction
Altitude	m	2,000 (contact factory for higher altitudes)
Withstand Voltage	Vac	Input to Output: 3.0kVac; Input to Case: 2.5kVac; Output to Case: 1.5kVac
Vibration	-	MIL-STD-810G 514.6 Cat 4, 10
Shock	-	MIL-STD-810G 516.6 Procedure I
<b>Other</b>		
Communications Interface	-	i <sup>2</sup> C (2 Address pins, CLK, Data, Alert) / PMBus Protocol (Refer to <a href="#">PFH500 PMBus Specifications</a> and <a href="#">GUI</a> )
Weight	g	225
Size (LxWxH)	mm	101.6 x 61.0 x 13.3
Size (LxWxH)	in	4.00 x 2.40 x 0.53
Warranty	yrs	3

# Last Time Buy April 30, 2026

PMBus Monitoring and Programming Functions	
Function	PMBus Commands
Output Voltage Data Format	Read only
Output Voltage Programming	Read / Write
Output Droop Rate (Current share)	Read only
Overvoltage Protection Set Point	Read / Write
Overtemperature Protection Fault Limit	Read / Write
Overcurrent Protection Set Point	Read / Write
Output Undervoltage Fault Trip Limit	Read / Write
Internal Temperature Monitor 1 (Output)	Read only
Internal Temperature Monitor 2 (Output)	Read only
Internal Temperature Monitor 3 (Input)	Read only
Internal Temperature Monitor 3 (Input)	Read only
High Voltage Bus Monitor	Read only
Output Voltage Monitor	Read only
Output Current Monitor	Read only
DC-DC Switching Frequency Monitor	Read only
Input Voltage Monitor	Read only
Input Current Monitor	Read only
Power Supply Status	Read only
Power Supply Fault Status	Read only
SMBAlert Mask	Read / Write
Remote On/Off	Write only
Manufacturing Information	Read only
Restore Data Functions	Read / Write

Notes:

See website for detailed specifications, evaluation data and instruction manual.

Specifications are typical based on nominal inputs, 25°C ambient temperature unless otherwise stated.

External components required. Refer to the product [Instruction Manual](#) for more detailed information.

(1) Total output power including the auxiliary output

**Last Time Buy April 30, 2026**

**PFH500A Basic Connection Diagram**

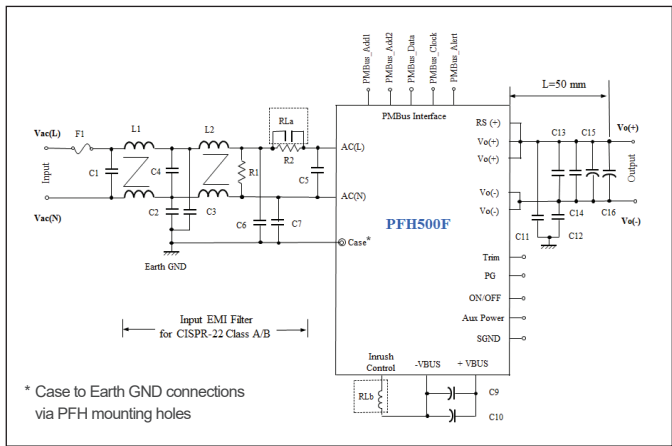

**PFH500A-28 Derating Curve**

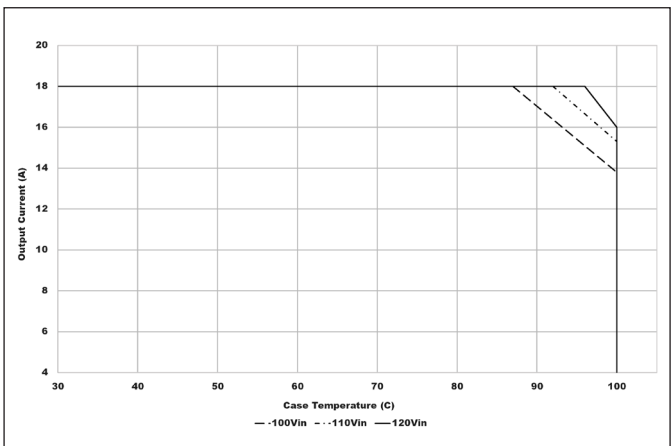

**Mechanical Specification**

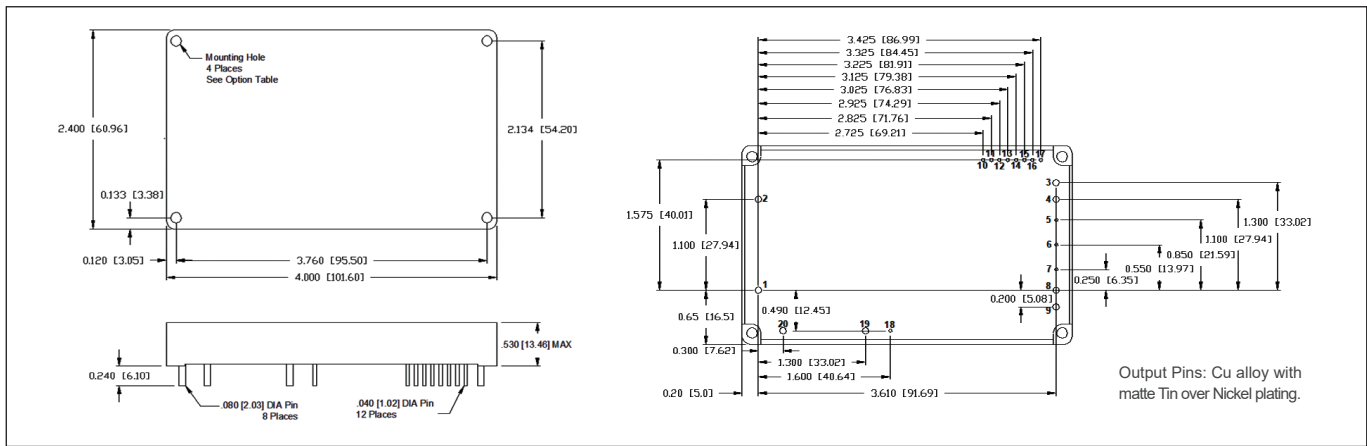

Pinout							
PIN	Function	PIN	Function	PIN	Function	PIN	Function
1	AC Input (Line) or AC (L)	7	Remote Sense (+) or RS (+)	13	PMBus Clock	19	- Boost Voltage Bus or - VBUS
2	AC Input (Neutral) or AC (N)	8	Vout (+)	14	PMBus Data	20	+ Boost Voltage Bus or + VBUS
3	Vout (-)	9	Vout (+)	15	PMBus Alert		
4	VOUT (-)	10	Power Good or PG	16	PMBus Address 2		
5	Remote ON/OFF	11	Secondary Signal GND or SGND	17	PMBus Address 1		
6	TRIM	12	Aux Power Supply or Aux Power	18	Inrush Control or Inrush CTL		

Last Time Buy April 30, 2026



**TDK-Lambda France SAS**

Tel: +33 1 60 12 71 65  
 tif.fr-powersolutions@tdk.com  
 www.emea.lambda.tdk.com/fr



**TDK-Lambda Americas**

Tel: +1 800-LAMBDA-4 or 1-800-526-2324  
 tia.powersolutions@tdk.com  
 www.us.lambda.tdk.com



**Italy Sales Office**

Tel +39 02 61 29 38 63  
 tif.it-powersolutions@tdk.com  
 www.emea.lambda.tdk.com/it



**TDK Electronics do Brasil Ltda**

Tel: +55 11 3289-9599  
 sales.br@tdk-electronics.tdk.com  
 www.tdk-electronics.tdk.com/en



**Netherlands**

tif.nl-powersolutions@tdk.com  
 www.emea.lambda.tdk.com/nl



**TDK-Lambda Corporation**

Tel: +81-3-6778-1113  
 www.jp.lambda.tdk.com



**TDK-Lambda Europe GmbH**

Tel: +49 7841 666 0  
 tlg.powersolutions@tdk.com  
 www.emea.lambda.tdk.com/de



**TDK-Lambda (China) Electronics Co. Ltd.**

Tel: +86 21 6485-0777  
 tlc.powersolutions@tdk.com  
 www.lambda.tdk.com.cn



**Austria Sales Office**

Tel: +43 2256 655 84  
 tlg.at-powersolutions@tdk.com  
 www.emea.lambda.tdk.com/at



**TDK-Lambda Singapore Pte Ltd.**

Tel: +65 6251 7211  
 tis.marketing@tdk.com  
 www.sg.lambda.tdk.com



**Switzerland Sales Office**

Tel: +41 44 850 53 53  
 tlg.ch-powersolutions@tdk.com  
 www.emea.lambda.tdk.com/ch



**TDK India Private Limited, Power Supply Division**

Tel: +91 80 4039-0660  
 mathew.philip@tdk.com  
 www.sg.lambda.tdk.com



**TDK-Lambda Europe GmbH**

Tel: Tel. +45 3222 8086  
 tlg.dk-powersolutions@tdk.com  
 www.emea.lambda.tdk.com/dk



**TDK-Lambda UK Ltd.**

Tel: +44 (0) 12 71 85 66 66  
 tlu.powersolutions@tdk.com  
 www.emea.lambda.tdk.com/uk



**TDK-Lambda Ltd.**

Tel: +9 723 902 4333  
 tli.powersolutions@tdk.com  
 www.emea.lambda.tdk.com/il-en

## Last Time Buy April 30, 2026

For Additional Information, please visit  
<https://product.tdk.com/en/power/>

