

MPM-10C

10W, Compact, High Isolation AC/DC Power Supplies

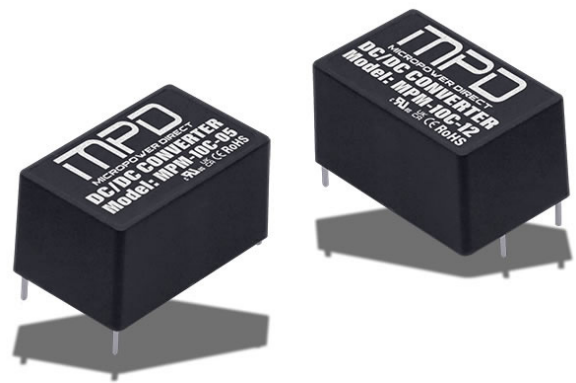

Key Features:

- 10W Output Power
- 85-305 VAC Input
- 4,200 VAC Isolation
- Compact Size
- Efficiency to 85%
- -40°C to +85°C Temp
- Meets EN 55032 B
- >3,200 kHour MBTF
- UL62368 Approval
- Reinforced Insulation

Electrical Specifications

Specifications typical @ +25°C, nominal input voltage & rated output current, unless otherwise noted. Specifications subject to change without notice.

Input					
Parameter	Conditions	Min.	Typ.	Max.	Units
Input Voltage Range	AC Input	85		305	VAC
	DC Input	100		430	VDC
Input Frequency		47		63	Hz
Input Current	115 VAC			0.23	A
	230 VAC			0.15	A
Inrush Current (Cold Start)	115 VAC		25		A
	230 VAC		40		A
Leakage Current	277 VAC / 50Hz			0.1	mA RMS
Fuse	A2S and A4S include fuse			2A/300V, slow blow, required	
Output					
Parameter	Conditions	Min.	Typ.	Max.	Units
Output Voltage Accuracy			±2		%
Line Regulation	Full Load		±0.5		%
Load Regulation	0 to 100% Load		±1		%
Ripple & Noise (20 MHz)			50	100	mV P - P
Standby Power Consumption	230VAC	3.3/5/9/12/15V	0.1		W
		24V	0.12		W
Hold-Up Time	115 VAC		8		ms
	230 VAC		40		ms
Temperature Coefficient			±0.02		%/°C
Over Voltage Protection	3.3/5VDC output			7.5	VDC
	9VDC output			15	VDC
	12/15VDC output			20	VDC
	24VDC output			30	VDC
Over Load Protection				≥110%Io, Self-Recovery	
Short Circuit Protection				Hiccup Mode (Autorecovery)	
General					
Parameter	Conditions	Min.	Typ.	Max.	Units
Isolation Voltage				4,200	VAC
EMI Characteristics					
Parameter	Standard	Criteria	Level		
Radiated Emissions, See Page 4	CISPR32/EN 55032				Class B
Conducted Emissions	CISPR32/EN 55032				Class B
Environmental					
Parameter	Conditions	Min.	Typ.	Max.	Units
Operating Temperature Range	Ambient	-40		+85	°C
Storage Temperature Range		-40		+85	°C
Cooling	Free Air Convection				
Storage Humidity	Non-condensing			95	%RH
Physical					
Case Size					See Mechanical Drawing (Page 5 & 6)
Case Material					Flame Retardant, Non-Conductive, Black Plastic (UL94V-0)
Weight					See Mechanical Drawing (Page 5 & 6)
Reliability Specifications					
Parameter	Conditions	Min.	Typ.	Max.	Units
MTBF	MIL HDBK 217F, 25°C, Gnd Benign	3.2			MHours
Safety Standards	UL/cUL 62368-1 recognition (UL certificate)				
Lead Temperature	Wave, 5 - 10s			260	°C
	Manual, 3 - 5s			360	°C



MicroPower Direct

46 Eastman Street
Unit 1
Easton, MA 02375
USA

T: (781) 344-8226
F: (781) 344-8481

E: sales@micropowerdirect.com
W: www.micropowerdirect.com



www.micropowerdirect.com

Model Number	Input		Output			Output Capacitive Load (μ F Max)	Efficiency (% Typ)
	Current (mA)		Voltage (VDC)	Current (mA, Max)	Power (W)		
	115 VAC	230 VAC					
MPM-10C-03	230	150	3.3	2600	8.6	6600	74
MPM-10C-05	230	150	5	2000	10	5000	79
MPM-10C-09	230	150	9	1100	10	3600	81
MPM-10C-12	230	150	12	830	10	2000	84
MPM-10C-15	230	150	15	660	10	820	84
MPM-10C-24	230	150	24	410	10	470	85

Notes:

1. The "tip and barrel method" is used for ripple and noise test, output parallel 10uF electrolytic capacitor and 1uF ceramic capacitor.
2. Unless otherwise specified, EMC performance indicators are tested according to typical connection circuit on page 4.
3. When the output terminal of the product needs to be connected to PE through a Y capacitor, or close to the metal frame, please refer to "EMI Connection for Class I Equipment."
4. Output short circuit protection is provided by a "hiccup mode" circuit. The unit recovers automatically when the fault condition is removed.
5. Input-output isolation is tested for 60 seconds with a leakage current of <5 mA.

6. Lead temperature is specified for 5 to 10 seconds for wave soldering with a tolerance of ± 5 °C. For manual soldering it is specified for 3 to 5 seconds with a tolerance of ± 10 °C.
7. For the **MPM-10C** series, the **-A2S** and **-A4S** options include a fuse of 2A/300V, slow blow.

For the A2S adapter board option, add the suffix "-A2S" to the model number (i.e. **MPM-10C-03-A2S**). See Page 6.

For the A4S adapter board option, add the suffix "-A4S" to the model number (i.e. **MPM-10C-03-A4S**). See Page 6.

Temperature Derating: 3.3/5 VOUT

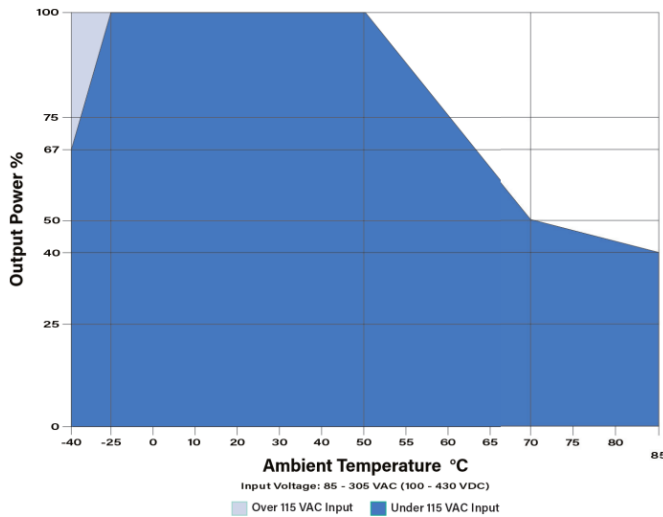

Temperature Derating: All Other Outputs

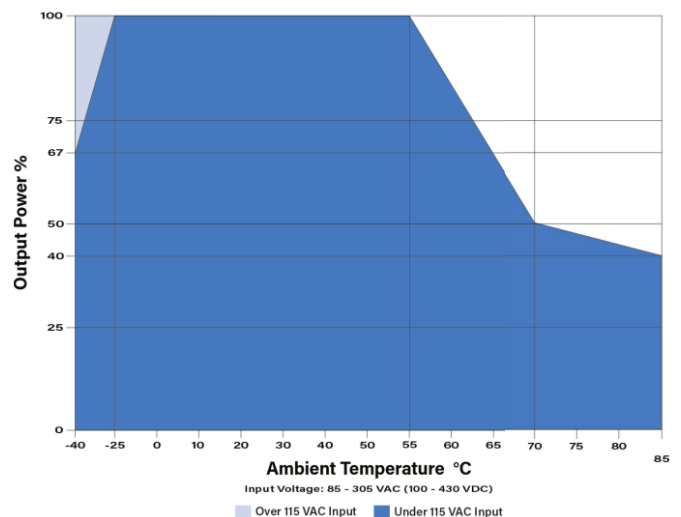

Input Voltage Derating

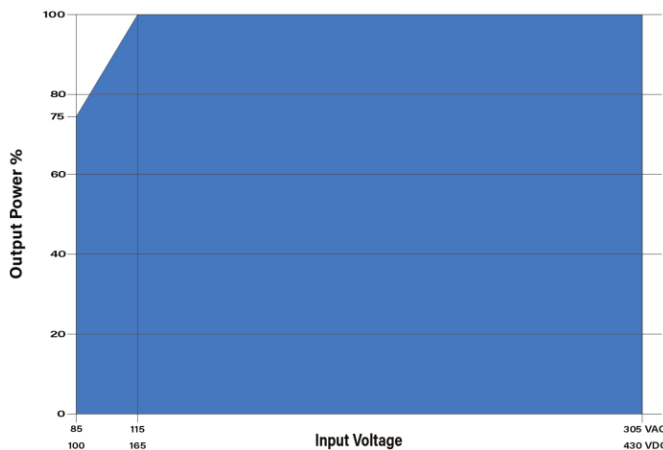

Altitude Derating

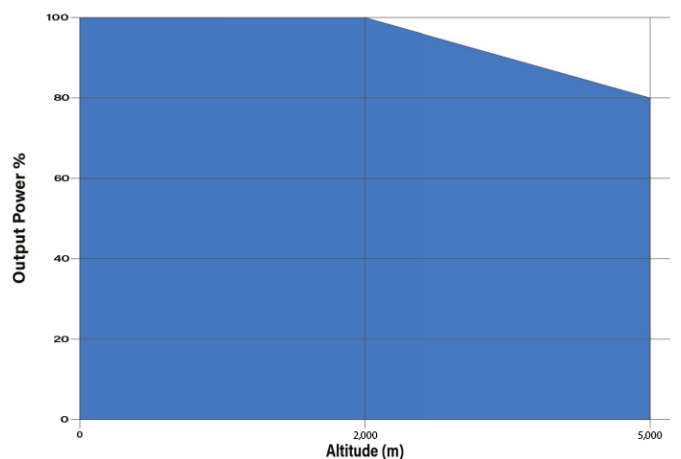

Efficiency vs Input Voltage: 5 VOUT Models

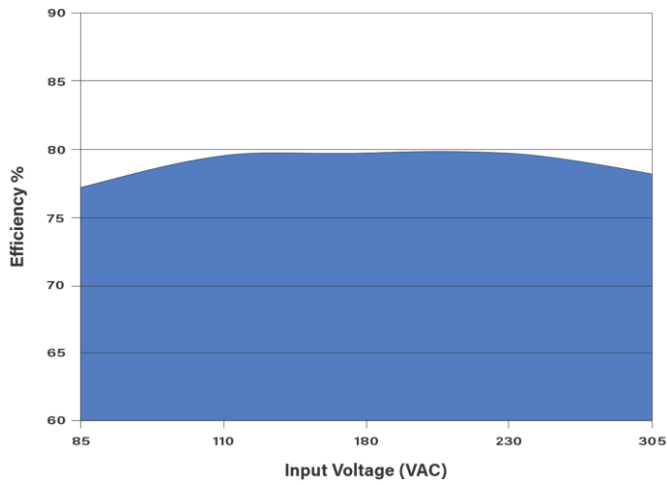

Efficiency vs Output Load: 5 VOUT Models

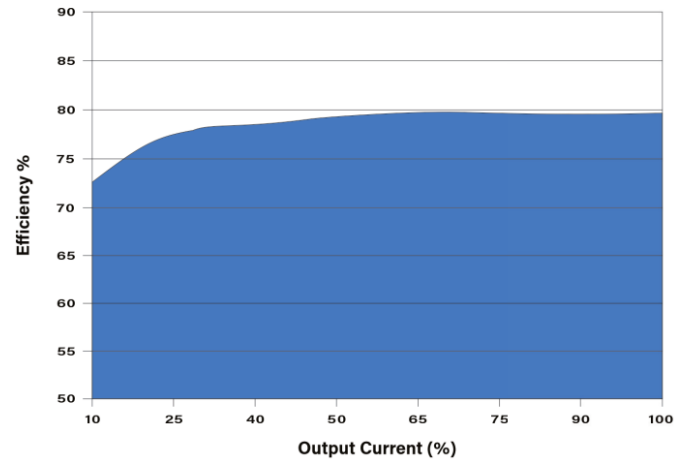

Efficiency vs Input Voltage: 12 VOUT Models

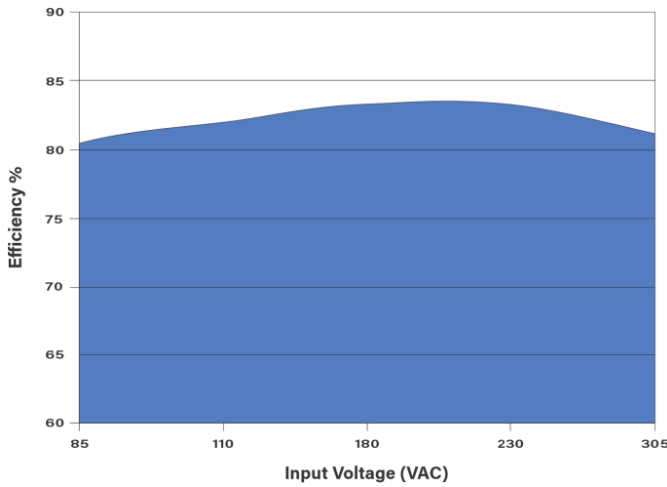

Efficiency vs Output Load: 12 VOUT Models

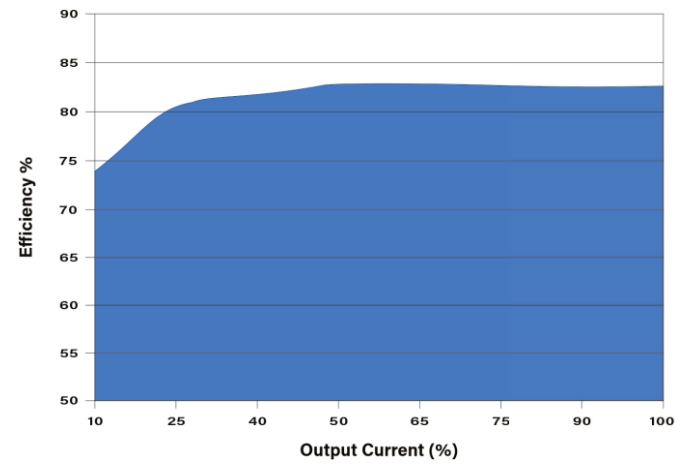

Efficiency vs Input Voltage: 24 VOUT Models

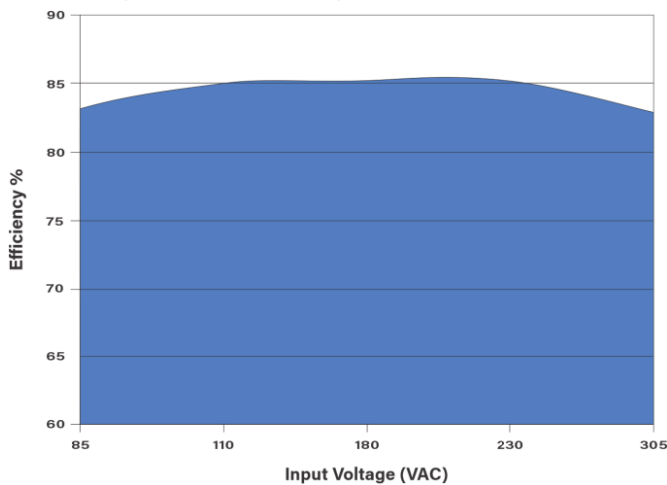

Efficiency vs Output Load: 24 VOUT Models

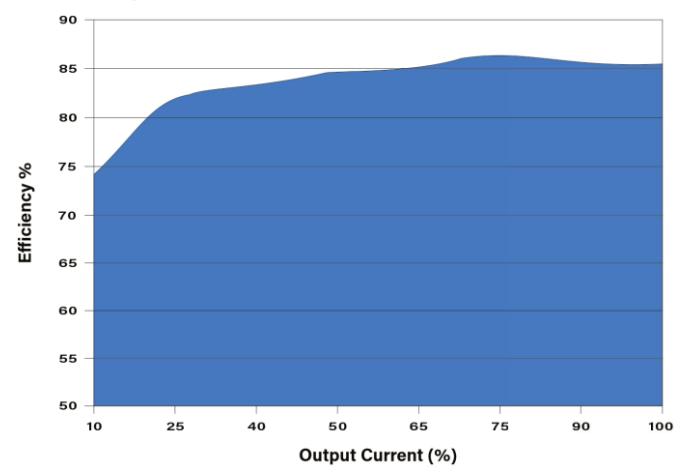

EMI Characteristics

Parameter	Standard	Criteria	Level
Radiated Emissions (RE)	CISPR32/EN55032		B
	EN55014-1		
Conducted Emissions (CE)	CISPR32/EN55032		B
	EN55014-1		
ESD	IEC/EN61000-4-2	B	Contact ±8kV/Air ±15kV
	EN55014-2	B	
RS	IEC/EN61000-4-3	A	10V/m
	EN55014-2	A	
EFT	IEC/EN61000-4-4	B	±2kV
	IEC/EN61000-4-4	B	±4kV
	IEC/EN61000-4-4	A	±4kV
	IEC/55014-2	B	
Surge	IEC/EN61000-4-5	B	line to line ±1kV
	IEC/EN61000-4-5	B	line to line ±2kV
	IEC/EN61000-4-5	A	line to line ±2kV/line to PE ±4kV
	EN55014-2	B	
CS	IEC/EN61000-4-6	A	10 Vr.m.s
	EN55014-2	A	
Voltage Dips, Short, Interruption	IEC/EN61000-4-11	B	0%, 70%
	EN55014-2	B	

Notes:

- To meet the requirements of CISPR32/EN55032 Class B, for Class II equipment, use the "Typical Connection" or the "EMI Connection for Class II Equipment" as shown below. Contact the factory for more information.
- To meet the requirements of IEC/EN61000-4-4 (±2 kV, Criteria B), use the "Typical Connection" as shown below. To meet EN61000-4-4 (±4 kV, Criteria B) use the "EMI Connection for Class II Equipment" as shown below. Contact the factory for more information. To meet EN61000-4-4 (±4 kV, Criteria A) use the "EMI Connection for Class I Equipment" as shown on the top of page 5.
- To meet the requirements of IEC/EN 61000-4-5 (±1 kV line to line, Criteria B), use the "Typical Connection" as shown below. Contact the factory for more information.
- To meet the requirements of IEC/EN 61000-4-5 (±2 kV line to line, Criteria B), use the "EMI Connection for Class II Equipment" as shown below. Contact the factory for more information.
- To meet the requirements of IEC/EN 61000-4-5 (±2 kV line to line / ±4 kV line to ground, Criteria A), use the "EMI Connection for Class I Equipment" as shown at the top of page 5.
- To meet the requirements of CISPR32/EN55032 Class B, for Class I equipment, use the "EMI Connection for Class I Equipment" as shown at the top of page 5. Contact the factory for more information.

Application Circuits

Typical Connection Diagram

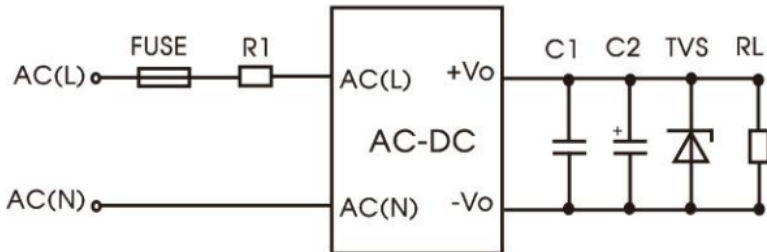

Part No.	C1	C2 (uF)	Fuse	R1	TVS
MPM-10C-03	1 uF/ 50V	220 uF/ 16V	2A/ 300V, slow- blow, req.	6.8 Ω/ 3W, wire- wound resistor, req.	SMBJ7.0A
MPM-10C-05					SMBJ7.0A
MPM-10C-09		100uF/ 25V			SMBJ12A
MPM-10C-12					SMBJ20A
MPM-10C-15		100uF/ 35V			SMBJ20A
MPM-10C-24					SMBJ30A

Output Filter Components:

We recommend using an electrolytic capacitor with high frequency, and low ESR rating for C2. Choose a capacitor voltage rating with at least 20% margin. C1 is a ceramic capacitor used for filtering high-frequency noise and TVS is a recommended suppressor diode to protect the application in case of a converter failure.

EMI Connection for Class II Equipment

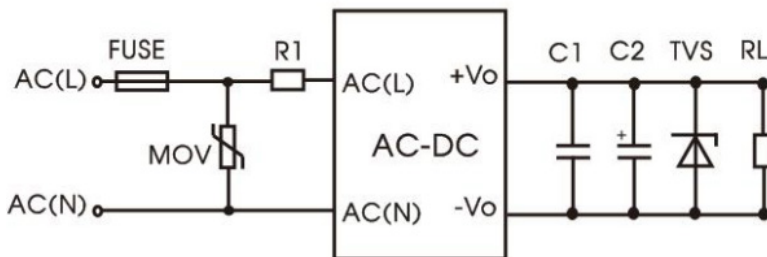

Component	Recommended Value
MOV	S14K350

EMI Connection for Class I Equipment

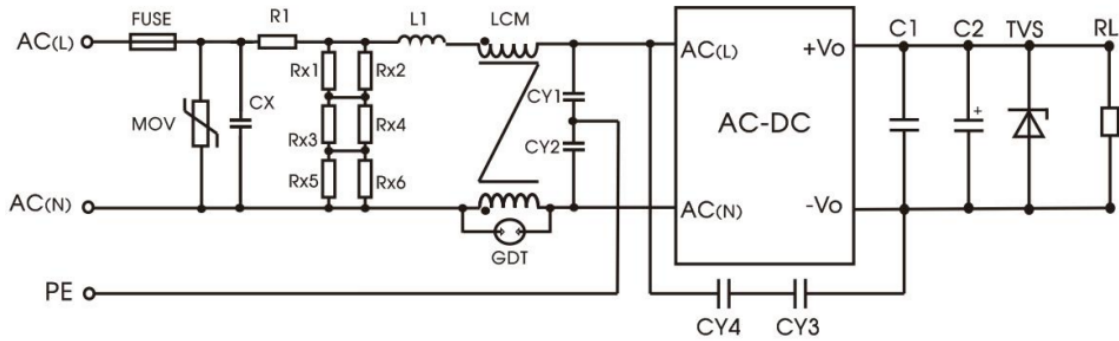

(Recommended when the output terminal of the product needs to be connected to PE or connected to PE through a Y capacitor)

Component	Recommended Value
FUSE	2A/300V, slow-blow, required
MOV	S14K350
CX	334K/305VAC
R1	12Ω/5W (wire-round resistor)
L1	1.2mH/0.5A
CY1/CY2	2.2nF/400VAC
CY3/CY4	1nF/400VAC
GDT	300V/1KA
LCM	20 mH

Note: Rx1/Rx2/Rx3/Rx4/Rx5/Rx6 is the bleeder resistance of CX, and the recommended resistance value is 1.5MΩ/150VDC.

Mechanical Diagrams

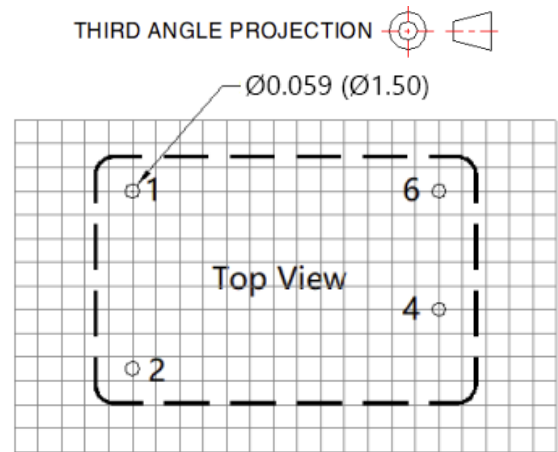
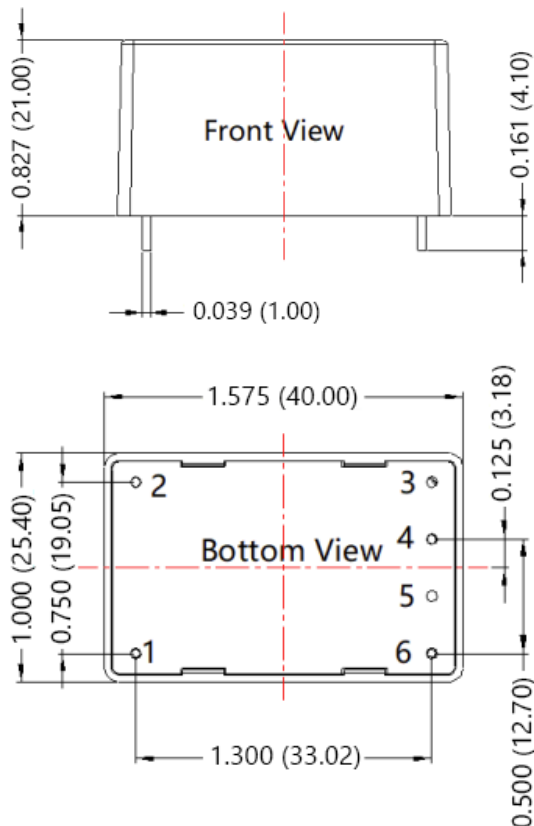

Note: Grid 0.1 * 0.1 in

Pin-Out	
Pin	Function
1	AC(L)
2	AC(N)
3	No Pin
4	+Vo
5	No Pin
6	-Vo

Notes:

- All dimensions are typical in inches (mm)
 - Pin diameter tolerances: ±0.004 (±0.10)
 - General tolerances: ±0.020 (±0.50)
- Weight:**
- Standard DIP Package: 1.20 oz (34g)

A2S Chassis Mechanical Diagram

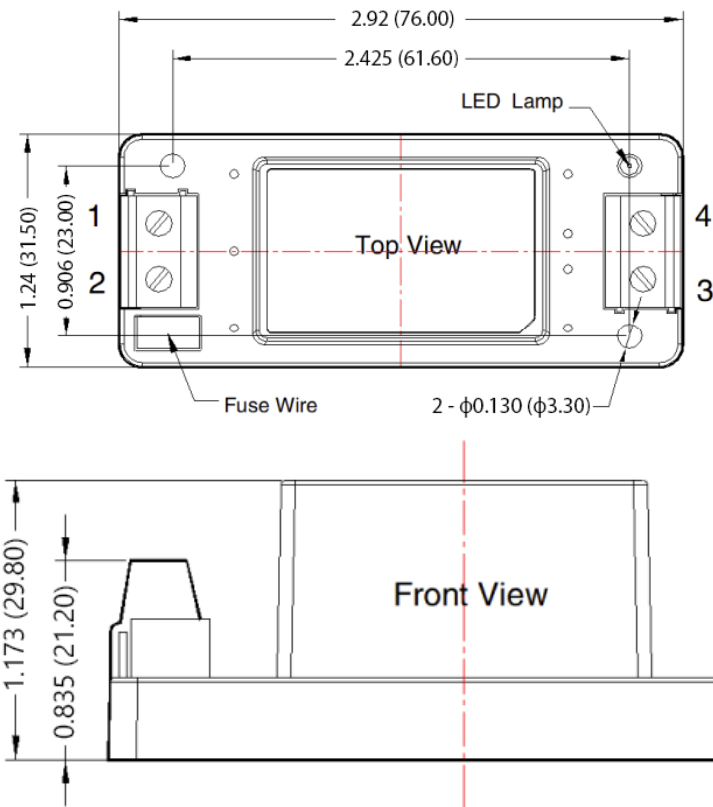

THIRD ANGLE PROJECTION

Pin-Out	
Pin	Function
1	AC(N)
2	AC(L)
3	-Vo
4	+Vo

Notes:

- All dimensions are typical in inches (mm)
- Wire range: 24-12 AWG
- Tightening torque: Max 0.4 N·m
- General tolerances: ± 1.00 (± 0.039)

Weight:

- A2S Chassis: 1.90 oz (54g)

A4S Din-Rail Mechanical Diagram

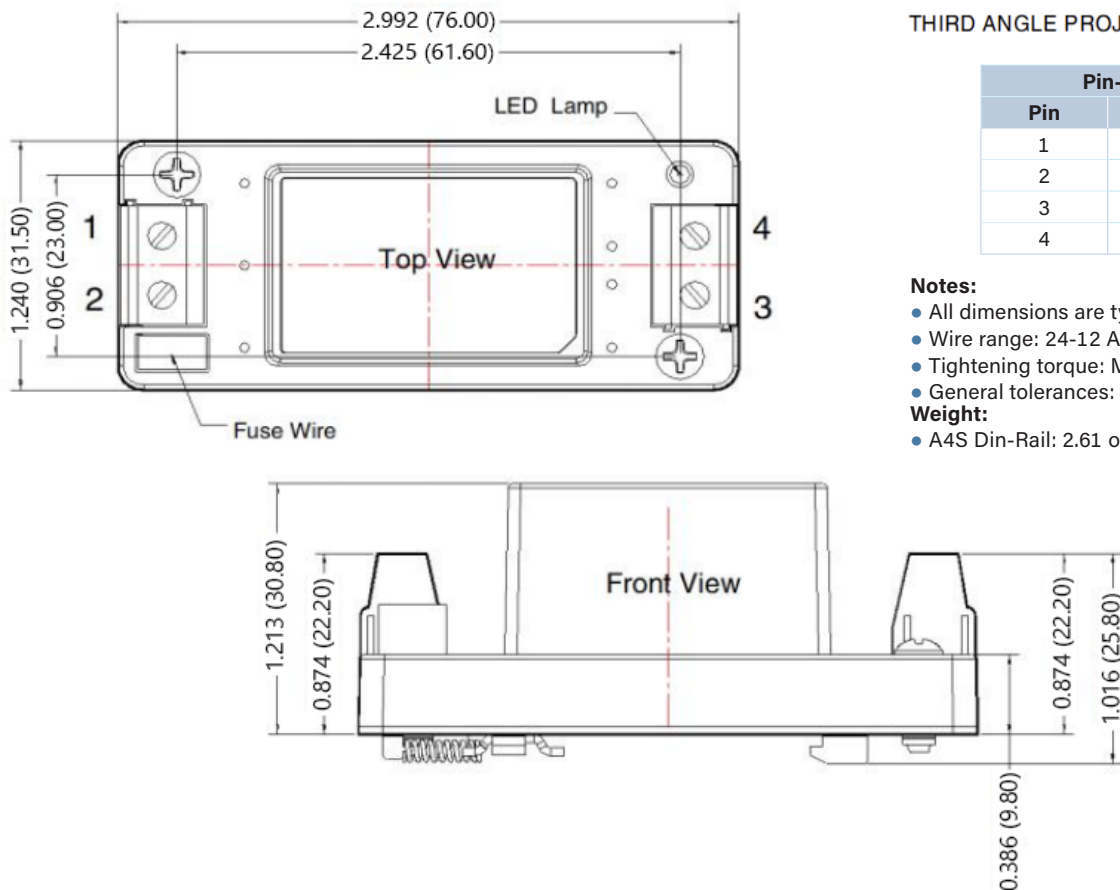

THIRD ANGLE PROJECTION

Pin-Out	
Pin	Function
1	AC(N)
2	AC(L)
3	-Vo
4	+Vo

Notes:

- All dimensions are typical in inches (mm)
- Wire range: 24-12 AWG
- Tightening torque: Max 0.4 N·m
- General tolerances: ± 1.00 (± 0.039)

Weight:

- A4S Din-Rail: 2.61 oz (74g)