



LFM300S SERIES 300 WATT AC-DC POWER SUPPLY WITH PFC

Features

- Universal Input Range 85~264Vac
- High Efficiency up to 94%
- Class I
- 25.4mm Low Profile Package
- No Load Input Power Consumption<0.3W
- Approval IEC/EN/UL 62368-1 Ed 3.0
- Approval EN 55032 and CISPR/FCC Class B
- Meets IEC/EN 60335-1
- Operating Altitude 5000m
- Continuous Short Circuit Protection
- Over Voltage Protection
- Over Temperature Protection
- High Power Density 37.1W/Inches³
- Active PFC Function
- Over Voltage Category OVC II & OVC III



MODEL NUMBER	OUTPUT VOLTAGE	OUTPUT CURRENT			RIPPLE & NOISE NOTE1	VOLTAGE ACCURACY NOTE2	VOLTAGE ADJ. RANGE	LINE REGULATION NOTE3	LOAD REGULATION NOTE4	% EFF. (Typ.) NOTE5
		With Fan NOTE6	With Conduction Cooling NOTE7							
			Baseplate	Cover						
LFM300S120	12 V	25 A	14.2 A	20.83 A	150 mV	±1%	11.4-12.6 V	±0.3%	±0.5%	93%
LFM300S150	15 V	20 A	11.35 A	16.6 A	150 mV	±1%	14.25-15.75 V	±0.3%	±0.5%	93%
LFM300S240	24 V	12.5 A	7.1 A	10.4 A	240 mV	±1%	22.8-25.2 V	±0.3%	±0.5%	94%
LFM300S280	28 V	10.7 A	6.07 A	8.90 A	280 mV	±1%	26.6-29.4 V	±0.3%	±0.5%	94%
LFM300S300	30 V	10 A	5.67 A	8.33 A	300 mV	±1%	28.5-31.5 V	±0.3%	±0.5%	94%
LFM300S480	48 V	6.25 A	3.54 A	5.20 A	480 mV	±1%	45.6-50.4 V	±0.3%	±0.5%	94%
LFM300S540	54 V	5.56 A	3.15 A	4.63 A	540 mV	±1%	51.3-56.7 V	±0.3%	±0.5%	93%

Note:

1. Add a 0.1uF ceramic capacitor and a 10uF E.L. capacitor to output for ripple & noise measuring @20MHz BW.
2. Voltage accuracy is set at full load.
3. Line regulation is measured from 100Vac to 240Vac with full load.
4. Load regulation is measured from 10% to 100% full load.
5. Typical efficiency at 230 Vac and full load at 25°C.
6. Forced air convection with 14CFM above 115Vac.
7. With addition cooling conduction plate, 22.8 by 22.8 cm with min. 0.2 cm thick, as below.



LFM300S Series

PART NUMBER

Series	Number of Outputs	Nominal Output Voltage	Type	Mounting Inserts
LFM300	O	XXX	X	-YZ
LFM300	S : Single	120 : 12V 150 : 15V 240 : 24V 280 : 28V 300 : 30V 480 : 48V 540 : 54V	B : With Baseplate C : With Cover	Blank : Through Hole C0 : Threaded Hole

Part Number Example:

LFM300S120C-C0: With Cover 300W, Single 12Vdc Output, Threaded Hole

LFM300S120B: With Baseplate 300W, Single 12Vdc Output, Through Hole



LFM300S Series

TECHNICAL SPECIFICATIONS

(All specifications are typical at nominal input, full load at 25°C unless otherwise noted.)

ABSOLUTE MAXIMUM RATINGS

PARAMETER	NOTES and CONDITIONS	Device	Min.	Typ.	Max.	Units
Input Voltage		All	85		264	V _{ac}
Operating Temperature	See derating curve	All	-40		80	°C
Operating Case Temperature	At the center of base plate (T _c = Case temperature)	All	-40		90	°C
Storage Temperature		All	-40		90	°C
Operating Altitude	IEC/EN/UL 62368-1 OVC II IEC/EN/UL 62368-1 OVC III	All			5000 2000	m

INPUT CHARACTERISTICS

PARAMETER	NOTES and CONDITIONS	Device	Min.	Typ.	Max.	Units
Operating Voltage Range		All	100		240	V _{ac}
Input Frequency Range		All	47		63	Hz
Maximum Input Current	100% Load, V _{in} =100V _{ac}	All			5.0	A
Leakage Current	Contact leakage current Earth leakage current	All			100 300	uA
Inrush Current	V _{in} =240V _{ac} , Cold Start @25°C	All			105	A
Power Factor	230V _{ac} @ Full load	All		0.92		

OUTPUT CHARACTERISTICS

PARAMETER	NOTES and CONDITIONS	Device	Min.	Typ.	Max.	Units
Output Voltage Set Point	V _{in} =Nominal V _{in} , I _o =I _o max., T _c =25°C	LFM300S120	11.88	12	12.12	V _{dc}
		LFM300S150	14.85	15	15.15	
		LFM300S240	23.76	24	24.24	
		LFM300S280	27.72	28	28.28	
		LFM300S300	29.7	30	30.3	
		LFM300S480	47.52	48	48.48	
Operating Output Current Range	V _{in} =85V _{ac} ~264V _{ac} , see derating curve	LFM300S120	0		25.0	A
		LFM300S150	0		20.0	
		LFM300S240	0		12.5	
		LFM300S280	0		10.7	
		LFM300S300	0		10.0	
		LFM300S480	0		6.25	
LFM300S540	0		5.56			
Holdup Time	V _{in} =115V _{ac}	All		12		ms
Output Voltage Regulation						
Load Regulation	10% Load to full load	All			±0.5	%
Line Regulation	V _{in} =High line to low line	All			±0.3	%
Output Voltage Adjustment	P _o ≤ max. rated power, I _o ≤ I _o max.	All	-5		+5	%
Over Voltage Protection	Latch off (AC recycle to reset)	LFM300S120			16	V _{dc}
		LFM300S150			20	
		LFM300S240			32	
		LFM300S280			35	
		LFM300S300			36	
		LFM300S480			59	
LFM300S540			63			
Over Current Protection	Auto recovery (output is rated load)	All	110	120	150	%



LFM300S Series

PARAMETER	NOTES and CONDITIONS	Device	Min.	Typ.	Max.	Units
Short Circuit Protection	Auto recovery	All				
Over Temperature Protection	Auto recovery	All				
Output Ripple and Noise	1. Add a 0.1uF ceramic capacitor and a 10uF aluminum electrolytic capacitor to output 2. Oscilloscope is 20MHz band width 3. Ambient Temperature=25°C	LFM300S120			150	mV
		LFM300S150			150	
		LFM300S240			240	
		LFM300S280			280	
		LFM300S300			300	
		LFM300S480			480	
		LFM300S540			540	
Load Capacitance	1. $V_{in}=115V_{ac}$ and $230V_{ac}$ 2. Output is max. load 3. Ambient temperature=25°C	LFM300S120			15400	uF
		LFM300S150			12200	
		LFM300S240			7800	
		LFM300S280			6600	
		LFM300S300			6200	
		LFM300S480			3870	
		LFM300S540			3400	
Efficiency	1. Input Voltage is 230Vac 2. Output is rated load 3. Ambient temperature=25°C	LFM300S120		93		%
		LFM300S150		93		
		LFM300S240		94		
		LFM300S280		94		
		LFM300S300		94		
		LFM300S480		94		
		LFM300S540		93		

ISOLATION CHARACTERISTICS

PARAMETER	NOTES and CONDITIONS	Device	Min.	Typ.	Max.	Units
Input to Output	1 Minute (without dielectric breakdown)	All			4250	V_{ac}
Input to Earth (Ground)	1 Minute (without dielectric breakdown)	All			2000	V_{ac}
Output to Earth (Ground)	1 Minute (without dielectric breakdown)	All			2000	V_{ac}
Isolation Resistance	Input to output	All	100			MΩ

FEATURE CHARACTERISTICS

PARAMETER	NOTES and CONDITIONS	Device	Min.	Typ.	Max.	Units
Switching Frequency	P_{out} =max. rated power	All		100		kHz

GENERAL SPECIFICATIONS

PARAMETER	NOTES and CONDITIONS	Device	Min.	Typ.	Max.	Units
MTBF	$I_o=100\%$; $T_a=25^\circ C$ per MIL-HDBK-217F $I_o=100\%$; $T_a=25^\circ C$ per Telcordia SR332	All	500		1690	k hours
Life Time (Detail Refer to Application Note)	Conduction cooling @75% Load, 40°C Fan cooling @75% Load, 40°C	All		112	159	k hours
Humidity	Non-condensing	All			93	% RH
Shock	Meet MIL-STD-810F Table 516.5, Table 516.5-I 10ms, each axis 3 times($\pm X$ 、 $\pm Y$ 、 $\pm Z$ axis)	All		75		g
Vibration	Meet MIL-STD-810F Table 514.5C-VIII, 15~2000Hz, X、Y、Z axis, 1 hour (each axis),. Total 3 hrs.	All		4		g



LFM300S Series

PARAMETER	NOTES and CONDITIONS	Device	Min.	Typ.	Max.	Units
Weight	Baseplate versions Covered versions	All		200 280		grams
Dimensions	Baseplate versions Covered versions	All	4.04x2.00x1.00 Inches (102.6x50.8x25.4 mm) 4.09x2.28x1.00 Inches (104.0x57.9x25.4 mm)			
Safety	Class I, IEC/EN/UL 62368-1					Ed. 3.0
EMC Emission	EN 55032, EN 61000-6-4, EN 61204-3, EN 61000-3-2, EN 61000-3-3, 47 CFR FCC Part 15					
Conducted Disturbance	EN 55032, 47 CFR FCC Part 15					Class B
Radiated Disturbance	EN 55032, 47 CFR FCC Part 15					Class B
Harmonic Current Emissions	EN 61000-3-2					Class A, D
Voltage Fluctuations & Flicker	EN 61000-3-3					Criterion A
EMC Immunity	EN 55035, EN 61000-6-2, EN 61204-3					
Electrostatic Discharge (ESD)	IEC 61000-4-2, Level 3: Air Discharge: $\pm 8kV$, Level 2: Contact Discharge: $\pm 4kV$					Criterion A
Radio-Frequency, Continuous Radiated Disturbance	IEC 61000-4-3, Level 3: 80~1000MHz, 10V/m					Criterion A
Electrical Fast Transient (EFT)	IEC 61000-4-4, Level 3: $\pm 2kV$					Criterion A
Surge	IEC 61000-4-5, Level 4: L-N: $\pm 2kV$, L-E (Ground): $\pm 4kV$					Criterion A
Conducted Disturbances, Induced by RF Fields	IEC 61000-4-6, Level 3: 0.15~80MHz, 10V					Criterion A
Power Frequency Magnetic Field	IEC 61000-4-8, Level 4: 30A/m					Criterion A
Voltage Dips	IEC/EN 61000-4-11, Dip: 30% Reduction IEC/EN 61000-4-11, Dip >95% Reduction					Criterion A
Voltage Interruptions	IEC/EN 61000-4-11, >95% reduction					Criterion B
Application Note Link	LFM300S Series App Notes					

CHARACTERISTIC CURVE

Power Derating Curve

Output Power vs Ambient Temperature

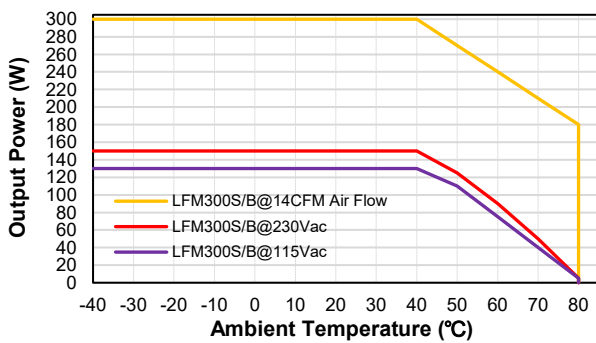

Output Power & Input Voltage

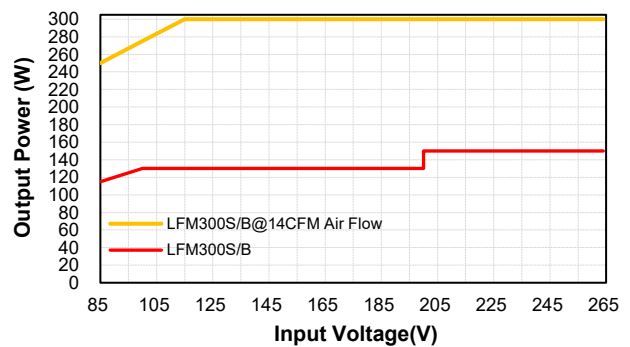

Output Power vs Ambient Temperature



Output Power & Input Voltage

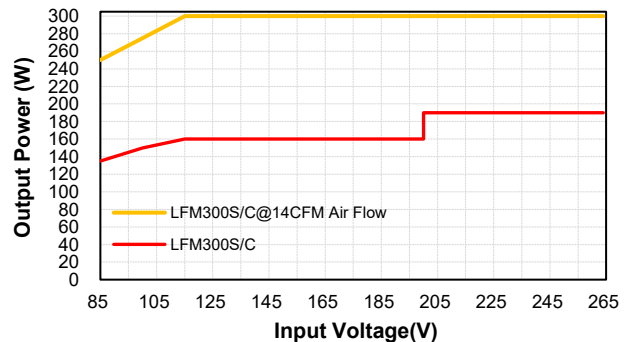



LFM300S Series

Conduction Convection with External Baseplate (22.8cmx22.8cmx0.2cm)

Output Power vs Ambient Temperature

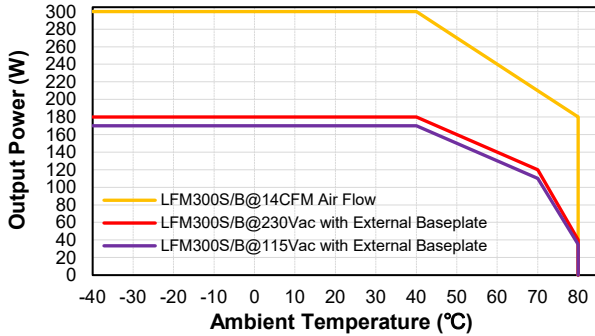

Output Power & Input Voltage

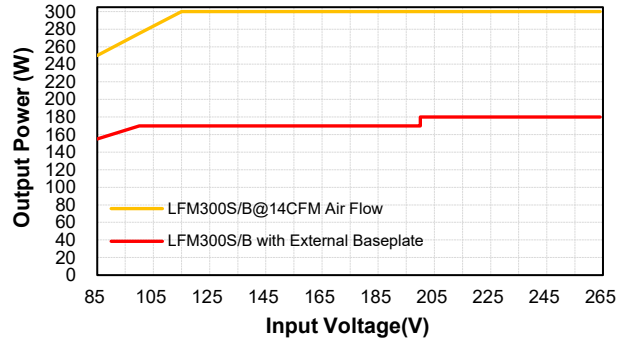

Output Power vs Ambient Temperature

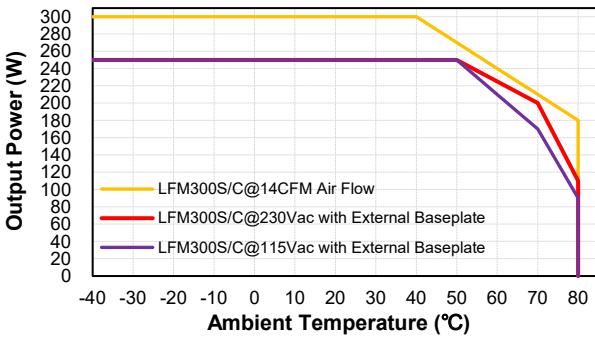

Output Power & Input Voltage

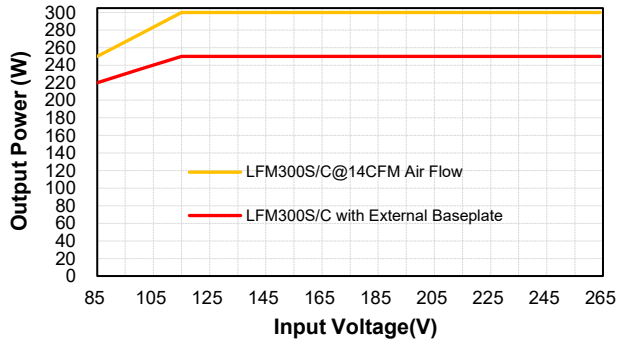

Output Power vs Case Temperature

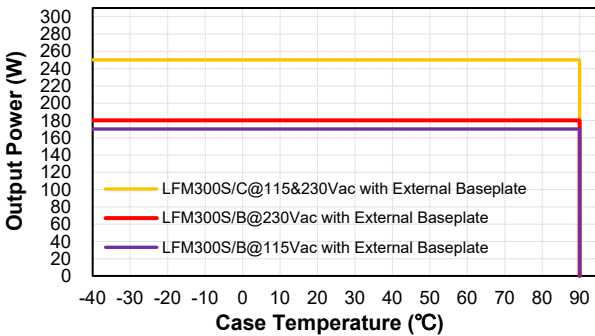

Performance Data

LFM300S120 (Eff Vs Io)

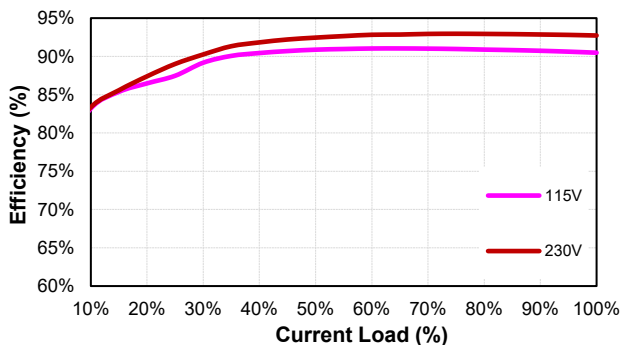

LFM300S150 (Eff Vs Io)

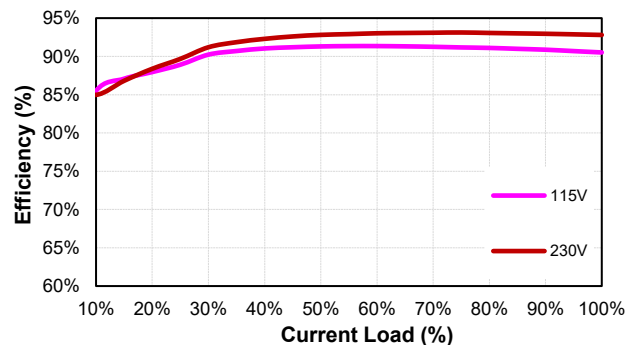



LFM300S Series

LFM300S240 (Eff Vs Io)

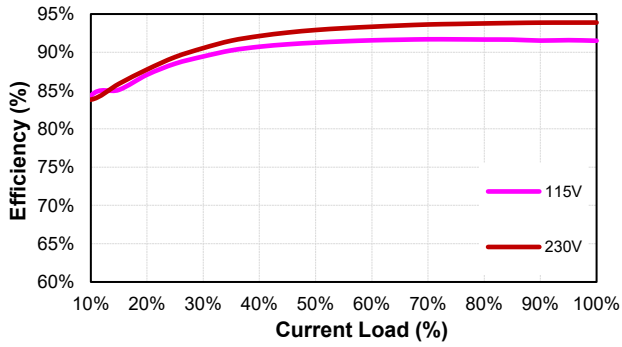

LFM300S280 (Eff Vs Io)

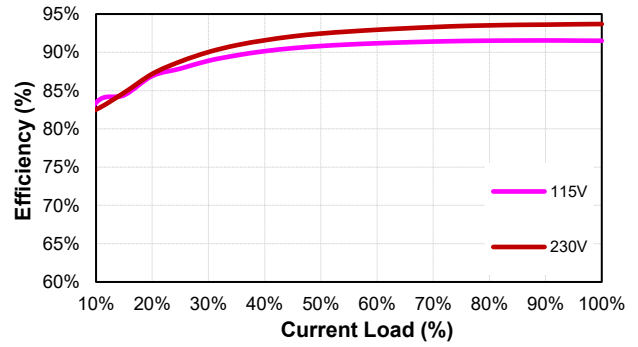

LFM300S300 (Eff Vs Io)

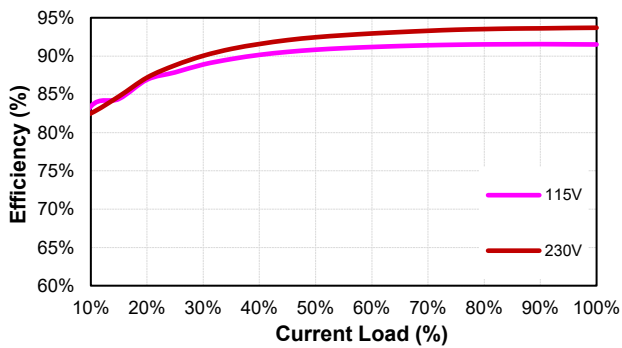

LFM300S480 (Eff Vs Io)

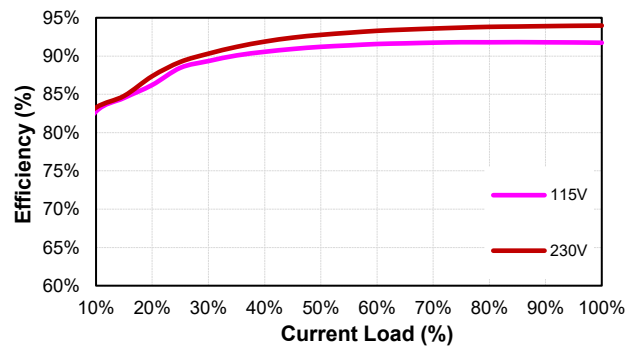

LFM300S540 (Eff Vs Io)

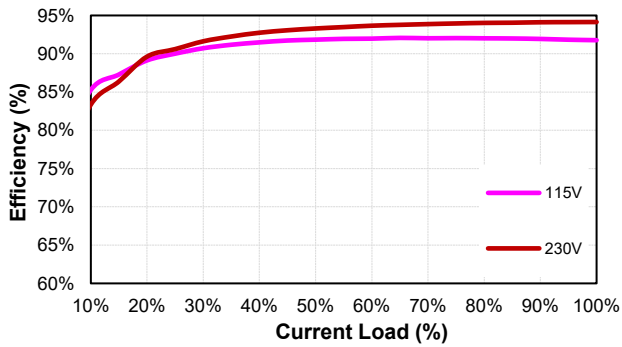



LFM300S Series

MECHANICAL SPECIFICATION

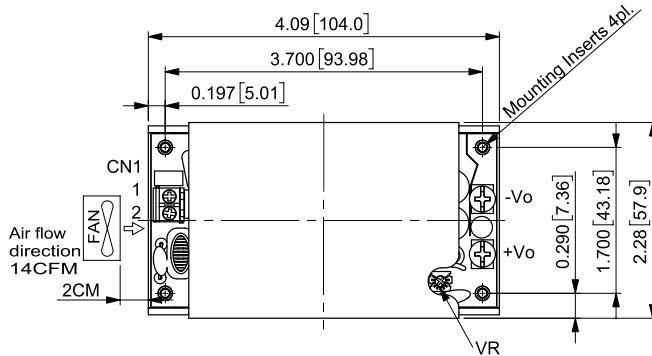

LFM300SXXXC LFM300SXXXC-C0

All Dimensions in Inches[mm]
Tolerance Inches: x.xx=±0.03, x.xxx=±0.020
Millimeters: x.x=±0.7, x.xx=±0.50

AC Input Connector(CN1):ECE ETB22

Pin	Function	Mating Wire Range
1	ACL	14~18 AWG
2	ACN	

DC Output Connector:KANG YANG PCB-58M4

Function	The screw locked torque
+Vo	M4 7kgf-cm
-Vo	

Mounting Inserts

Series	Option
Blank	∅3.2 Through depth 10.5mm
-C0	M3x0.5 Threaded depth 10.5mm

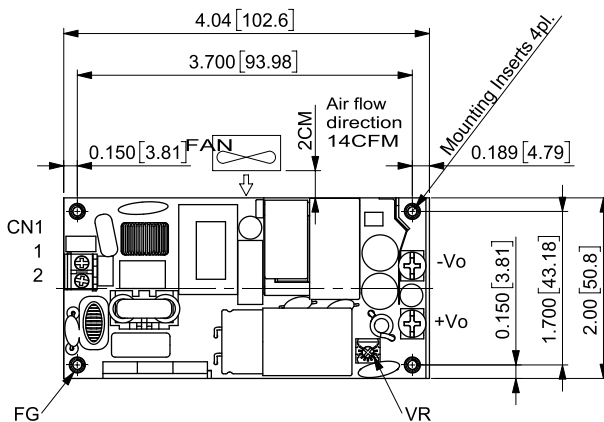
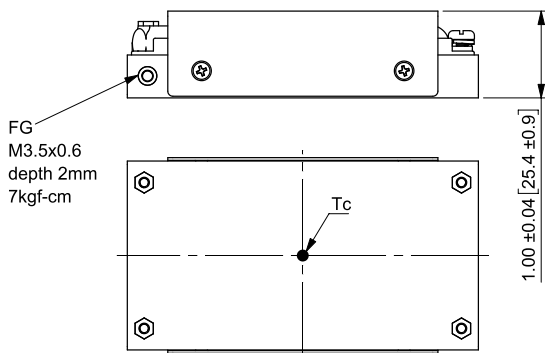

LFM300SXXXB LFM300SXXXB-C0

All Dimensions in Inches[mm]
Tolerance Inches: x.xx=±0.03, x.xxx=±0.020
Millimeters: x.x=±0.7, x.xx=±0.50

AC Input Connector(CN1):ECE ETB22

Pin	Function	Mating Wire Range
1	ACL	14~18 AWG
2	ACN	

DC Output Connector:KANG YANG PCB-58M4

Function	The screw locked torque
+Vo	M4 7kgf-cm
-Vo	

Mounting Inserts

Series	Option
Blank	∅3.2 Through depth 7.8mm
-C0	M3x0.5 Threaded depth 7.8mm

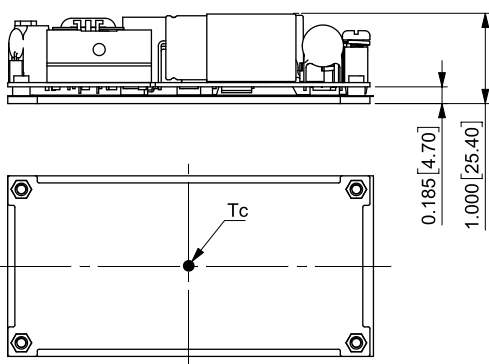

CINCON Electronics Co. Ltd.
Add: 14F, No. 306, Sec.4, Hsin Yi Rd., Taipei, Taiwan
Tel: 886-2-27086210
Fax: 886-2-27029852
E-mail: sales@cincon.com.tw
Web: www.cincon.com