

Click to
ORDER
samples

AMEL60-HAGY

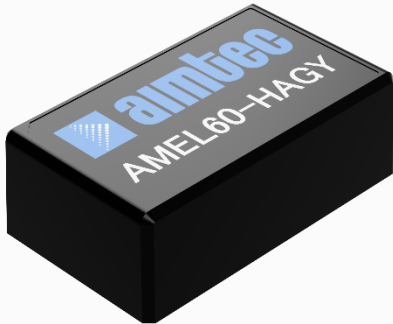

Encapsulated

The AMEL60-HAGY series is an efficient 60W AC-DC power supply module. Offering a commercial input voltage range of 90-264VAC, output voltage ranges from 5-48V, low power consumption, high efficiency, high reliability and safer isolation.

This new series offers great operating temperatures, from -30°C to 85°C with full power up to 50°C and features an isolation of 4000VAC for improved reliability and system safety. Furthermore, a high MTBF of 800,000h, output short circuit protection (OSCP), output over-current protection (OCP) and an output over-voltage protection (OVP) come standard with the series.

The AMEL60-HAGY is suitable for grid power, industrial instrumentation and controls, communication, and civil applications.

Features

- Universal Input: 90 - 264VAC
- Operating Temp: -30 °C to +85 °C
- High isolation voltage: 4000VAC
- Output short circuit, over-current, over-voltage protection
- Low no-load power consumption of 0.15W
- Designed to meet: IEC/EN/UL62368-1, IEC/EN60335-1, EN61558-1



Summary

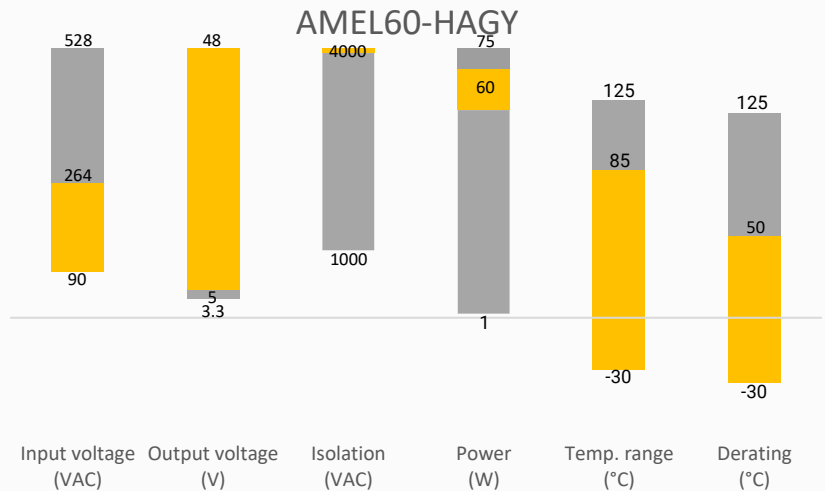

Training



Product Training Video
(click to open)



Press Release

Coming Soon!

Application Notes

Applications



Power Grid



Industrial



Telecom

Models & Specifications

Single Output						
Model	Input Voltage (VAC/Hz)	Max Output wattage (W)	Output Voltage (V)	Output Current max (A)	Maximum capacitive load (μ F)	AVG. Efficiency (%)
AMEL60-5SHAGY	90-264/50-60	50	5	10	20000	84
AMEL60-12SHAGY	90-264/50-60	60	12	5	8000	87.5
AMEL60-15SHAGY	90-264/50-60	60	15	4	5000	89
AMEL60-24SHAGY	90-264/50-60	60	24	2.5	4200	89.5
AMEL60-48SHAGY	90-264/50-60	60	48	1.25	800	91

Note: Use suffix "ST" for chassis mounting (ex. AMEL60-5SHAGY-ST is chassis mounting version).

Input Specifications				
Parameters	Conditions	Typical	Maximum	Units
Input current	115VAC		1.8	A
	230VAC		1	A
Inrush current	115VAC, cold start	30		A
	230VAC, cold start	65		A
Leakage	264VAC		0.25	mA

Output Specifications				
Parameters	Conditions	Typical	Maximum	Units
Voltage accuracy		± 2.5		%
Line regulation	Full load	± 0.5		%
Load regulation	5Vout and 12Vout	± 1		%
	others	± 0.5		%
Ripple & Noise*	20MHz bandwidth, 5Vout		80	mV p-p
	20MHz bandwidth, 12Vout		120	mV p-p
	20MHz bandwidth, 15Vout		120	mV p-p
	20MHz bandwidth, 24Vout		150	mV p-p
	20MHz bandwidth, 48Vout		240	mV p-p
Hold up time	115VAC	5		ms
	230VAC	50		ms

* Ripple and Noise are measured at 20MHz bandwidth with a 47 μ F electrolytic capacitor and a 0.1 μ F ceramic capacitor. Please refer to the application note for specific details.

Isolation Specification				
Parameters	Conditions	Typical	Maximum	Units
Tested I/O voltage	60 sec	4000		VAC
Resistance	500VDC	>100		M Ω

General Specifications				
Parameters	Conditions	Typical	Maximum	Units
Overvoltage category	OVC II (According to EN62368-1; altitude up to 2000 meters)			

Over current protection	Hiccup, Auto recovery	≥ 115	160	% of Iout
Over voltage protection	5Vout, Shut off o/p voltage, clamping by zener diode		7.5	VDC
	12Vout, Shut off o/p voltage, clamping by zener diode		16.5	VDC
	15Vout, Shut off o/p voltage, clamping by zener diode		24	VDC
	24Vout, Shut off o/p voltage, clamping by zener diode		34	VDC
	48Vout, Shut off o/p voltage, clamping by zener diode		65	VDC
Short circuit protection	Hiccup, Continuous, Auto recovery			
Operating temperature	See derating graph	-30 to +85		°C
Storage temperature		-40 to +85		°C
No-load power consumption		0.15		W
Power Derating	+40 °C to +70 °C, 5Vout	1.67		%/°C
	+50 °C to +85 °C, others	2.43		%/°C
	90VAC to 100VAC	2		%/VAC
Temperature coefficient	(0~50°C)	±0.03		%/°C
Cooling	Free air convection			
Humidity	Non-condensing	10	95	% RH
	Non-condensing, Operating	20	90	% RH
Vibration	PCB mounting: 10~ 500Hz, 2G 10min./1cycle, period for 60min. each along X, Y, Z axes With optional -ST mounting plate: 10~500Hz, 5G 10min./1cycle, period for 60min. each along X, Y, Z axes			
Weight	PCB mountable models	195		g
	With optional -ST mounting plate	260		
Dimensions (L x W x H)	PCB mountable models	3.43 x 2.05 x 1.18inches (87.0 x 52.0 x 30 mm)		
	With optional -ST mounting plate	4.30 x 2.07 x 1.33 inches (109.3 x 52.7 x 33.9 mm)		
MTBF	> 800 000 hrs (MIL-HDBK -217F, t=+25°C)			
NOTE: All specifications in this datasheet are measured at an ambient temperature of 25°C, humidity<75%, nominal input voltage and at rated output load unless otherwise specified.				

Safety Specifications

Parameters

Agency approval	UL/EN/TUV BS EN 62368-1	
Standards	Information technology Equipment	Design to meet IEC62368-1, IEC/EN60335-1, EN61558-1
	EMC Emission	EN55032 (CISPR32) CNS13438 Class B, EN61000-3-2 Class A, EN61000-3-3
	EMC Immunity	BS EN/EN61000-4-2,3,4,5,6 Level 3, criteria A; BS EN/EN61000-4-8 Level 4, criteria A; BS EN/EN61000-4-11

Derating

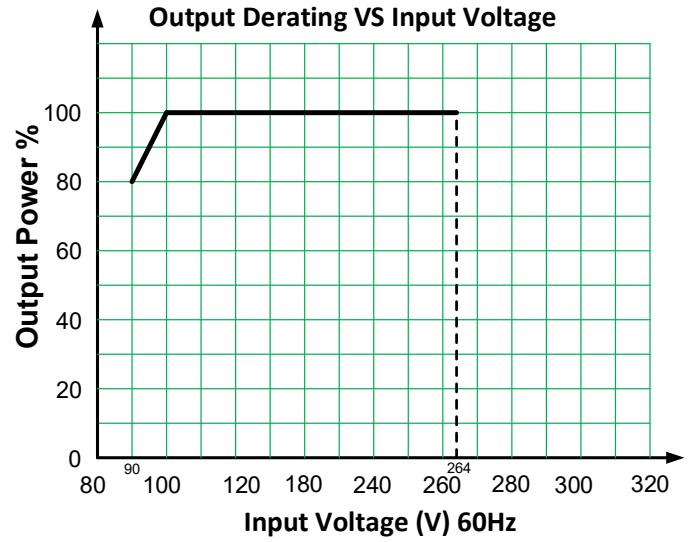
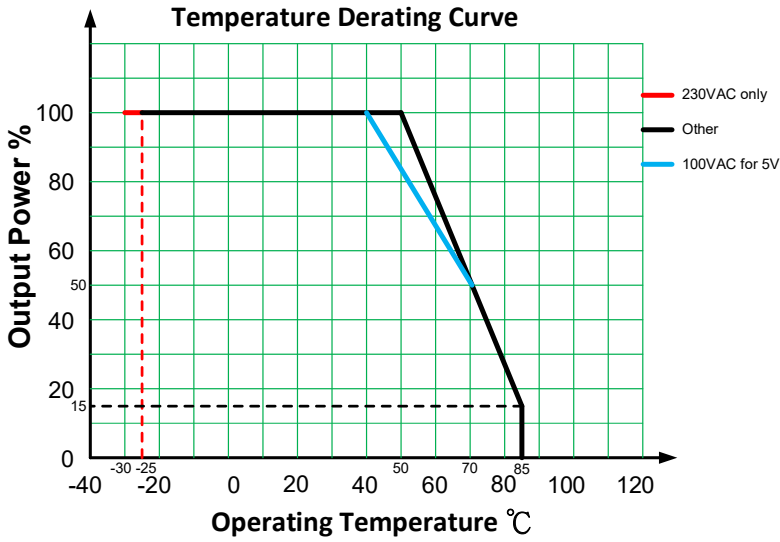

Dimensions

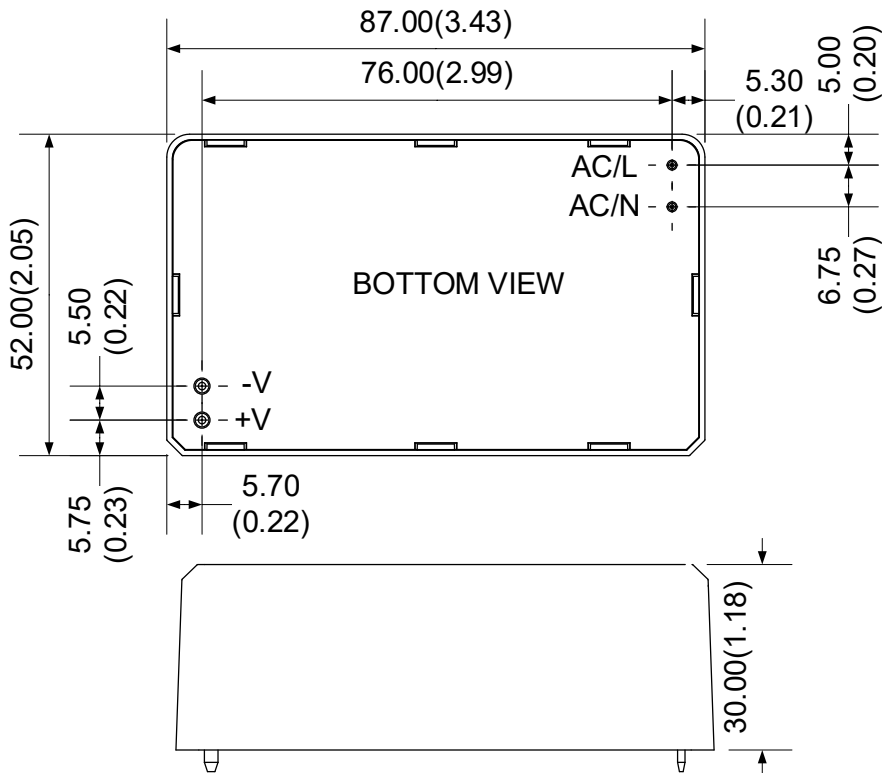

Note:
Unit: mm(inch)
General tolerance: ± 0.50 (± 0.02)
Pin diameter tolerances: ± 0.10 (± 0.04)

Dimensions with Optional - ST

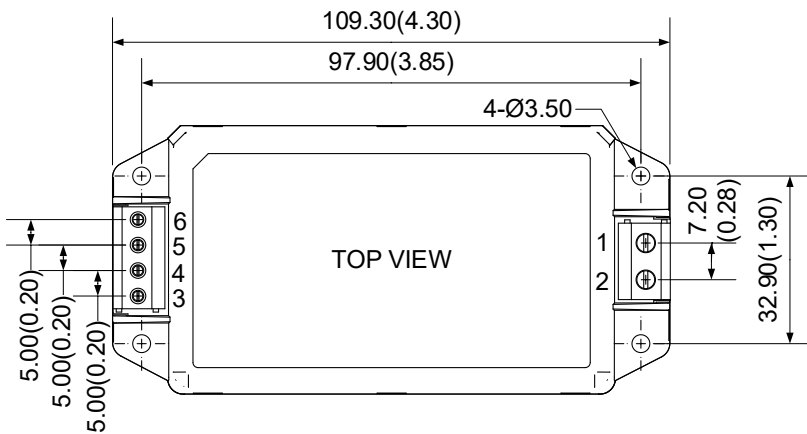
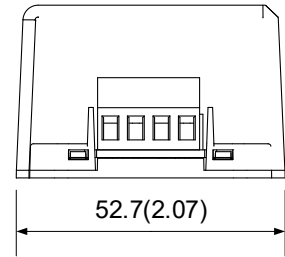
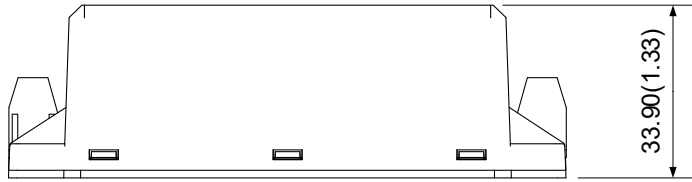

Pin Output Specifications	
Pin	Single
1	AC Input (N)
2	AC Input (L)
3	+V Output
4	+V Output
5	-V Output
6	-V Output

Note:

Unit: mm(inch)

General tolerance: ± 1.00 (± 0.04)

Connection wire diameter: 24-12AWG

Screw clamp unit: M2.5 Max 0.4 N*m

NOTE: 1. Datasheets are updated as needed and as such, specifications are subject to change without notice. Once printed or downloaded, datasheets are no longer controlled by Aimtec; refer to www.aimtec.com for the most current product specifications. 2. Product labels shown, including safety agency certifications on labels, may vary based on the date manufactured. 3. Mechanical drawings and specifications are for reference only. 4. All specifications are measured at an ambient temperature of 25°C, humidity < 75%, nominal input voltage and at rated output load unless otherwise specified. 5. Aimtec may not have conducted destructive testing or chemical analysis on all internal components and chemicals at the time of publishing this document. CAS numbers and other limited information are considered proprietary and may not be available for release. 6. This product is not designed for use in critical life support systems, equipment used in hazardous environments, nuclear control systems or other such applications which necessitate specific safety and regulatory standards other than the ones listed in this datasheet. 7. Warranty is in accordance with Aimtec's standard Terms of Sale available at www.aimtec.com.