

Features

- Wide voltage input 85-305VAC/120-430VDC
- DIP
- Operating temperature range: -40°C~+85°C
- Isolation voltage 3000/4000VAC 5mA 1Minute
- Internal SMD design
- High flame retardant plastic shell
- Heat dissipation mode: natural air cooling
- It has good shielding anti-interference performance and electromagnetic compatibility, lightning protection, output over current, short circuit protection, overheat protection, self-recovery and other functions

Product Picture

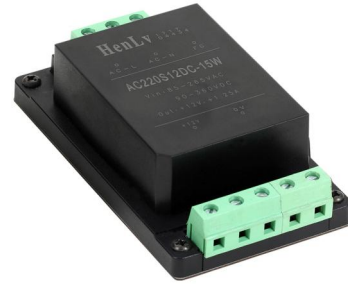

EMC-EN55032
EN55035
LVD-EN62368

Dimensions

AC220S(D)(TD)__ZDK-15W Series Dimensions

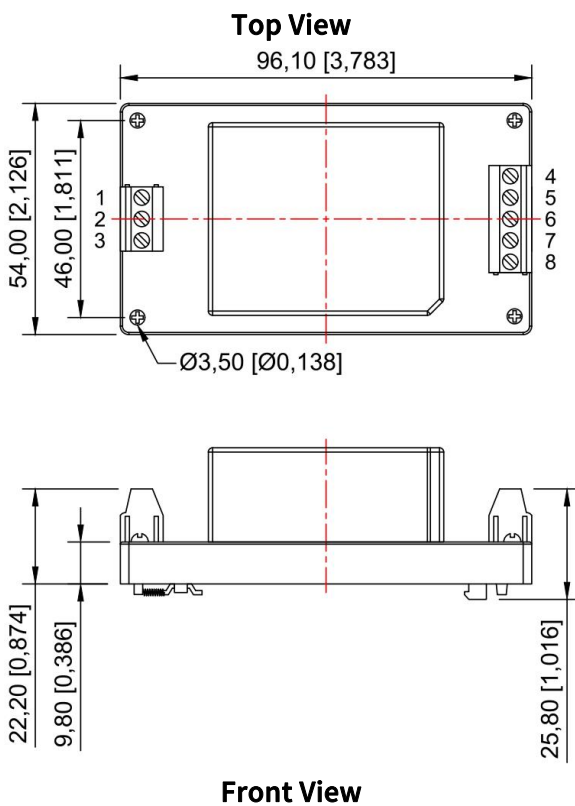

Pin mode			
Pin	Single(S)	Dual(D)	Dual non-shared ground(TD)
1	FG	FG	FG
2	AC(N)	AC(N)	AC(N)
3	AC(L)	AC(L)	AC(L)
4	0V	-XXVDC	0V1
5	NC	NC	+XXVDC
6	NC	COM	NC
7	NC	NC	0V2
8	+XXVDC	+XXVDC	+XXVDC

Note:

Size unit: mm[inch]

Unmarked tolerance: $\pm 0.25[\pm 0.01]$

Wire bond strength: 24-12 AWG

Tightening torque: Max 0.4 N-m

Guide rail: TS35

The device layout is for reference only.

AC220S(D)(TD)__ZD-15W Series Dimensions

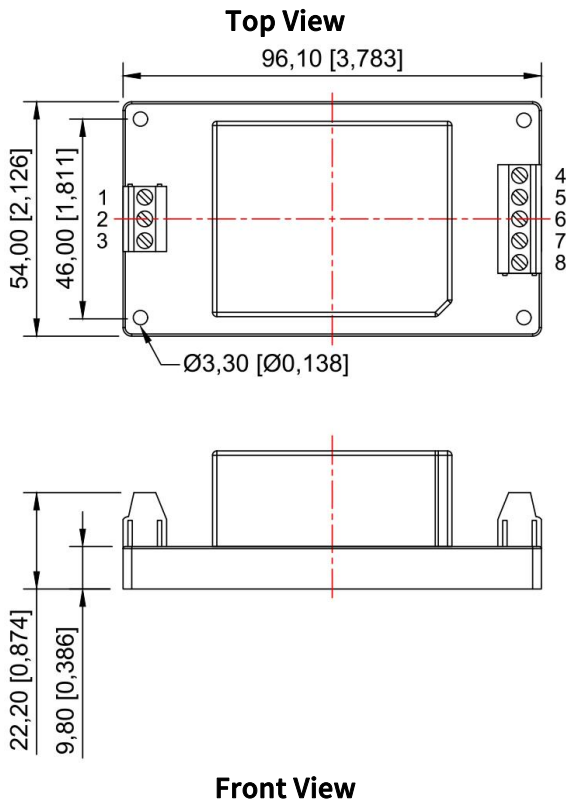

Pin mode			
Pin	Single(S)	Dual(D)	Dual non-shared ground(TD)
1	FG	FG	FG
2	AC(N)	AC(N)	AC(N)
3	AC(L)	AC(L)	AC(L)
4	0V	-XXVDC	0V1
5	NC	NC	+XXVDC
6	NC	COM	NC
7	NC	NC	0V2
8	+XXVDC	+XXVDC	+XXVDC

Note:
 Size unit: mm[inch]
 Unmarked tolerance: $\pm 0.25[\pm 0.01]$
 Wire bond strength: 24-12 AWG
 Tightening torque: Max 0.4 N·m
 The device layout is for reference only.

Application

Industrial control and remote DC power supply system, switching system, AC/DC(5V products), railway communication, communication interface converter, cellular telephone, semiconductor laser, display screen, monitoring equipment, petrochemical, portable instrument, medical instrument, automatic control device, burglar alarm, handheld instrument, digital circuit, IC card meter, air conditioning computer controller, LED production Products, digital products, power adapters, etc.

Selection Guide

Model	Input(V)	Output (V $\pm 2\%$)	Current (mA)	Efficiency (%)	Isolation (VAC)	Weight (g ± 0.5)	Certification	
AC220S05ZD(K)-15W	85-305VAC (120-430VDC)	5	3000	84	3000/4000			
AC220S09ZD(K)-15W		9	1666	85	3000/4000			
AC220S12ZD(K)-15W		12	1250	85	3000/4000			
AC220S15ZD(K)-15W		15	1000	85	3000/4000			
AC220S24ZD(K)-15W		24	625	86	3000/4000			
AC220D05ZD(K)-15W		± 5	± 1500	84	3000/4000			
AC220D09ZD(K)-15W		± 9	± 833	85	3000/4000			
AC220D12ZD(K)-15W		± 12	± 625	85	3000/4000			
AC220D15ZD(K)-15W		± 15	± 500	85	3000/4000			
AC220D24ZD(K)-15W		± 24	± 316	86	3000/4000			
AC220TD0505ZD(K)-15W		5	5	Customizatio	84	4000		

			n				
AC220TD0512ZD(K)-15W	5	12	Customization	85	4000		
AC220TD0524ZD(K)-15W	5	24	Customization	86	4000		DIP

Note: The company for customers to customize any input and output module power supply, if you have special needs, please call our company, unless otherwise specified, input =Vi, the characteristics of the module power supply should meet the requirements of Table 1, and applicable to the full temperature range (-40°C≤Tc≤85°C)

Electrical Specifications

Specifications	Symbol	Conditions Vi , -40°C≤Tc≤85 (Unless otherwise specified)	Min	Min	Unit
Output Voltage	Vo	Full Load	Vo-2%	Vo+2%	V
Output Current	Iomax	—	—	P(Power)/ U(Output voltage)	A
Output Ripple Voltage	Vp-p	Full Load, Vi, BW=20MHz, Normal Temperature	80	250	mV
Output Noise Voltage	Vp-p	Full Load, Vi, BW=20MHz, Normal Temperature	100	300	mV
Voltage Regulation	Sv	Vimin, Vi, Vimax, Full Load	—	≤±1	%
Load Adjustment	Si	Vi, Io=(10%~100%)Iomax	—	≤±1.5	%
Insulation Resistance	Rl	Input-output, Insulation Voltage: 500VDC	100	—	MΩ

Mechanical Specifications

Size	96.10 x 54.00 mm
------	------------------

General Specifications

EMC Specifications	Magnetic Field Sensitivity Test	GB6833.2-87
	Electrostatic Discharge Sensitivity Test	GB6833.3-87
	Radiation Sensitivity Test	GB6833.5-87
	Conduction Sensitivity Test	GB6833.6-87
Temperature Drift	≤±0.03%/°C	
Storage Temperature	-40°C~125°C	
Input Frequency	47Hz~63Hz	
Humidity	20%~95%RH	
Leakage Current	5mA(max)	
MTBF	>500000H	

Typical Specifications Curves

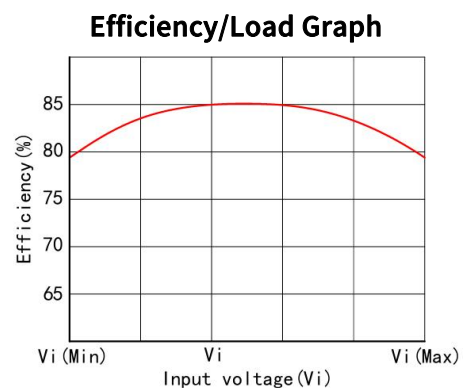
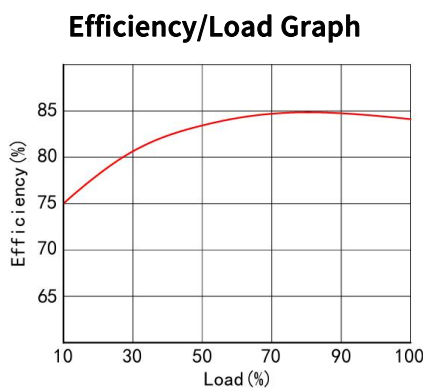
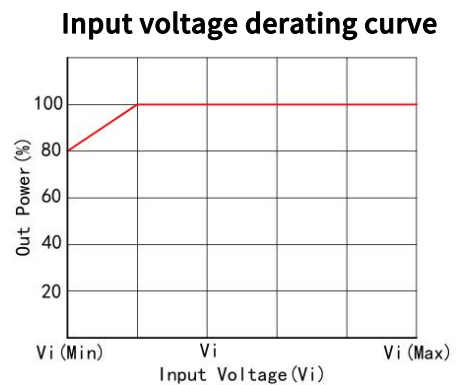
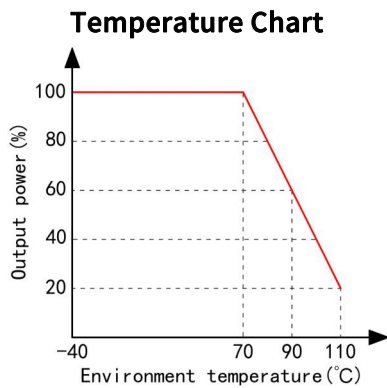

Typical Application

Design Reference

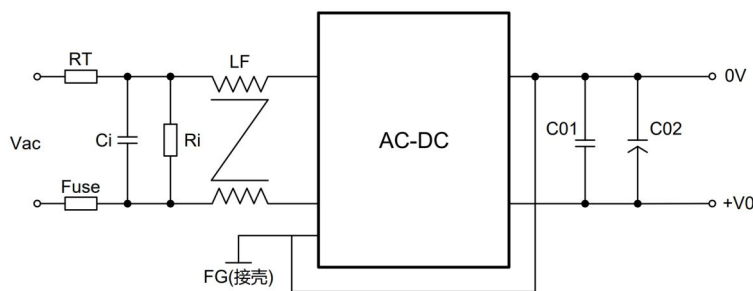

Recommendation Test

Filter: In some circuits that are sensitive to noise and ripple, an external filter capacitor can be connected to the DC/DC input and output terminals to reduce the impact of ripple on the system, but the value of the filter capacitor should be appropriate, if the capacitor is too large, it is likely to cause startup problems, for each output, under the condition of ensuring safe and reliable operation, the maximum capacitance of the filter capacitor can be referred to the external capacitance table. In order to obtain very low ripple, an "LC" filter network can be connected to the input and output end of the DC/DC converter, so that the filtering effect will be better, and it should be noted that the size of the inductance value and the frequency of the "LC" filter network should be staggered from the frequency of the DC/DC module power supply to avoid mutual

interference. For each output, under safe and reliable working conditions, the recommended capacitive load value is shown in (Table 1).

Input voltage (Vin+)	C01	C02	RT	Ci(UF)	Ri(KR)	LF(mH)
85-305V	104M/50V	1000uF/16V	8D-7	0.1/275V	560	8-10

Recommended output max capacitive load value table (Table 1)

Note: Please note that the main grounding of the output and the grounding of the load are connected to the ground, so that even if the product has problems, it will not cause harm to the human body. The ground requirements for the auxiliary roads are isolated and can be grounded without grounding.

Precautions

Package

This series of modules are packed in shockproof and anti-static foam.

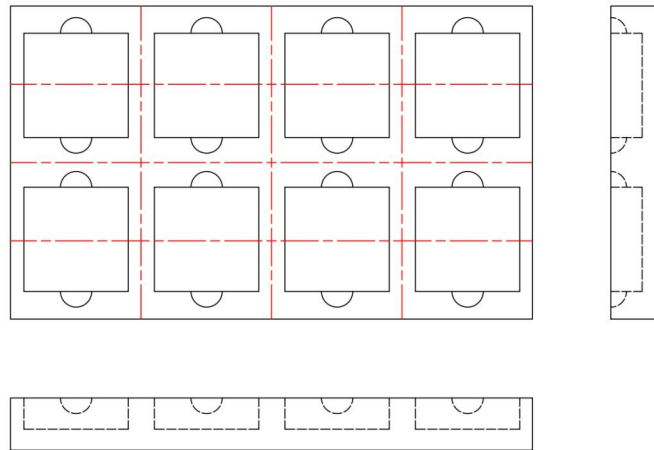

Transport

The package containing the module is allowed to be transported by any means of transport, which should avoid direct rain and snow and mechanical damage.

Storage

The module should be stored in a warehouse where the ambient temperature is -40 degrees ~ 125 degrees, the relative humidity is 20%~95%, and the surrounding environment is free from acidic, alkaline and other harmful gases.

Note: The above are the performance indicators of the product series listed in this manual. Some indicators of non-standard products may exceed the above requirements, so if there is any inconsistency between the manual and the product specification documents, please refer to the specification documents. If you have special needs, please contact us directly.