

JR-W Series

# Waterproof Circular Connectors



Waterproof



Corrosion Prevention



Wide Variation



# Features

---

## 1. Waterproof Design

Achieves IPX7 and IPX8 waterproof standards when fully mated.

IPX7 certified for immersion at 1 meter for 30 minutes, and  
IPX8 certified for immersion at 2 meters for 14 days, ensuring  
durability in wet conditions.

## 2. Corrosion Resistance

The exterior shell is coated with corrosion resistant plating and can be used in various environments.

## Product Specifications

Rated Current	Shell Size	No. of Pos.	Rated Current
	13	5	5A
	16	7	10A
		10	5A
	25	3	15A
4		30A	
24		5A	

Rated Voltage	Shell Size	No. of Pos.	Rated Voltage
	13	5	100V AC, 140V DC
	16	7	
		10	
	25	3	300V AC, 420V DC
		4	
		24	3
4			

Operating Temperature	-25 to +85°C (Note)
Storage Temperature	-10 to +60°C

Item	Specification	Conditions
Contact Resistance	5m Ω Max. JR16-10pos. crimp type: 10m Ω Max. JR25-3pos.: 3m Ω Max.	Measured at 1A DC
Insulation Resistance	1,000M Ω Min. JR25-4pos.: 10,000M Ω Min.	Measured at 500V DC
Withstanding Voltage	No insulation breakdown	1,000V AC for 1 min. JR25-4pos.: 3,000V AC for 1 min.
Vibration Resistance	No electrical discontinuity of 10 μs or more	10 to 55Hz/cycle, amplitude 0.75mm, 2 hours each in 3 axis directions
Shock Resistance	No electrical discontinuity of 10 μs or more	Acceleration 490m/s <sup>2</sup> , duration 11ms, 3 times each in 6 axis directions
Mating Durability	Contact Resistance: 5m Ω Max. JR16-10pos. crimp type: 10m Ω Max. JR25-3pos.: 3m Ω Max.	500 times
Temperature Cycles	Insulation resistance: 1,000M Ω Min. JR25-4pos.: 10,000M Ω Min.	-40°C : 30 minutes ⇒ normal temperature: 10 to 15 minutes ⇒ 100°C : 30 minutes ⇒ normal temperature: 10 to 15 minutes, Repeated for 5 cycles. JR25-3pos.: -30°C : 2 hours ⇒ normal temperature: 2 hours ⇒ 80°C : 2 hours ⇒ normal temperature: 2 hours. Repeated for 50 cycles.
Humidity Resistance	Insulation resistance: 10M Ω Min. (High Humidity) 100M Ω Min. (Dry) JR25-4pos.: 100M Ω Min. (High Humidity) 1,000M Ω Min. (Dry)	96 hours at temperature of 40°C and humidity of 90% to 95%
Waterproof	No water immersion into connector	Mated: Immersed in 1.8 meters water depth for 48 hours

Note: -40°C products are also available. Please contact a Hirose sales representative for details.

## Materials / Finish

Item	Material	Finish
Outer Shell	Aluminum Alloy, Brass	Black Chromium Plating
Insulator	PPS	-
Contact	Copper Alloy	Silver Plating
Waterproof Packing	Silicone Rubber	-

## Product Number Structure

Refer to the chart below when determining the product specifications from the product number.  
Please select from the product numbers listed in this catalog when placing orders.

### ■ Plug / Receptacle

**JR 13 WP A - 3 P C (##)**

① ② ③ ④ ⑤ ⑥ ⑦ ⑧ ⑨

### ■ Cord Clamp

**JR 13 WCC A - 4 (##)**

① ② ③ ④ ⑧ ⑨

① Series Name	JR	⑥ Contact Gender	P: Male Contact S: Female Contact
② Shell Size	Outer diameter of the case of the plug mating part	⑦ Contact Assembly	None: Solder Termination C: Crimp Termination
③ Shell Type	WP: Waterproof Plug WR: Waterproof Receptacle WCC: Waterproof Cramp	⑧ Applicable Cable Diameter	
④ Shell Variation	Connectors are distinguished by A, B, or C if a shell variation is applied in the same form.	⑨ Other Specifications	A two-digit character is added to indicate other specifications as needed.
⑤ No. of Pos.			

## Plug

### Plug

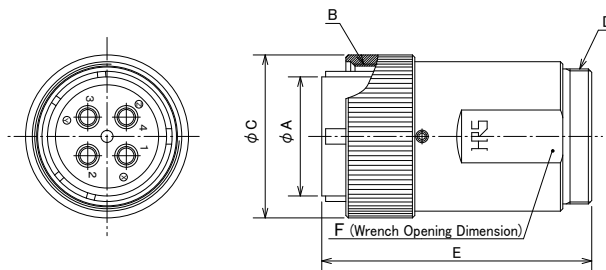

(Representative Example)

JR25WPH-4S

### Solder Type

Unit : mm

Part No.	HRS No.	No. of Pos.	$\phi A$	B	$\phi C$	D	E	F	Purchase Unit
JR13WPH-5P	CL0114-0062-0-00	5	12.7	M18 × 1	21.8	M16 × 0.75	44.7	17	40pcs per tray
JR16WPH-7P	CL0114-0072-0-00	7	16.3	M22 × 1	25.8	M20 × 0.75	46.5	21	
JR25WPH-4P	CL0114-2185-0-00	4	24.7	M30 × 1	33.8	M28 × 0.75	56	29	30pcs per tray
JR25WPH-24P	CL0114-0077-0-00	24							
JR13WPH-5S	CL0114-0063-0-00	5	12.7	M18 × 1	21.8	M16 × 0.75	44.7	17	40pcs per tray
JR16WPH-7S	CL0114-0073-0-00	7	16.3	M22 × 1	25.8	M20 × 0.75	46.5	21	
JR25WP-3S(71)	CL0114-2159-0-71	3	24.7	M30 × 1	33.8	M28 × 0.75	56	29	30pcs per tray
JR25WPH-4S	CL0114-2183-4-00	4							
JR25WPH-24S	CL0114-0078-0-00	24							

Note: When using the plug, be sure to use it in combination with the cord clamp.

### Crimp Type

Unit : mm

Part No.	HRS No.	No. of Pos.	$\phi A$	B	$\phi C$	D	E	F	Contact Dia.	Purchase Unit
JR16WP-10SC(31)	CL0114-2122-0-31	10	16.3	M22 × 1	25.8	M20 × 0.75	46.5	21	1	40pcs per tray

## Receptacle



JR25WRH-4P

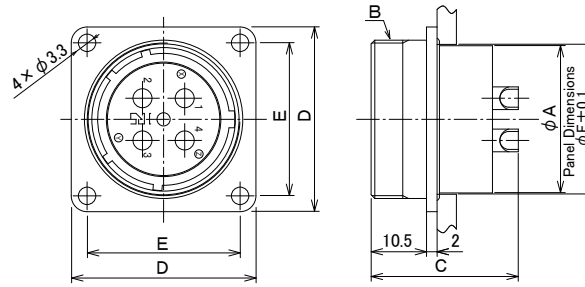

(Representative Example)

### Solder Type (Square Flange Type)

Unit : mm

Part No.	HRS No.	No. of Pos.	φ A	B	C	D	E	φ F	Purchase Unit
JR13WRH-5P	CL0114-0066-0-00	5	15.9	M18 × 1	26.1	26	20	16.3	20pcs per bag
JR16WRH-7P	CL0114-0074-0-00	7	19.9	M22 × 1	26.6	29	23	20.3	
JR25WR-3P(71)	CL0114-2158-7-71	3	27.9	M30 × 1	29.1	35	29	28.3	30pcs per tray
JR25WRH-4P	CL0114-2184-7-00	4			28				
JR25WRH-24P	CL0114-0079-0-00	24			26.1				
JR13WRH-5S	CL0114-0067-0-00	5	15.9	M18 × 1	27	26	20	16.3	20pcs per bag
JR16WRH-7S	CL0114-0075-0-00	7	19.9	M22 × 1	28	29	23	20.3	
JR25WRH-4S	CL0114-2186-2-00	4	27.9	M30 × 1		27	35	29	28.3
JR25WRH-24S	CL0114-0080-0-00	24							

### Crimp Type (Square Flange Type)

Unit : mm

Part No.	HRS No.	No. of Pos.	φ A	B	C	D	E	φ F	Contact Dia.	Purchase Unit
JR16WR-10PC(31)	CL0114-2130-8-31	10	19.9	M22 × 1	25.1	29	23	20.3	1	20pcs per bag

### Solder Type (Jam Nut Rear Panel Mount, Hex Nut Type)



JR25WRHA-4P

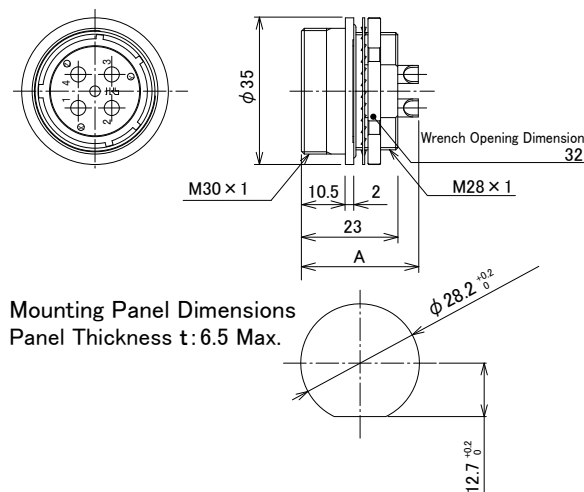

(Representative Example)

Unit : mm

Part No.	HRS No.	No. of Pos.	A	Purchase Unit
JR25WRHA-4P	CL0114-1136-9-00	4	28	10pcs per tray
JR25WRHA-4S	CL0114-1135-6-00			

## Cord Clamp

### Cord Clamp (Standard Type)



JR13WCC-6(71)

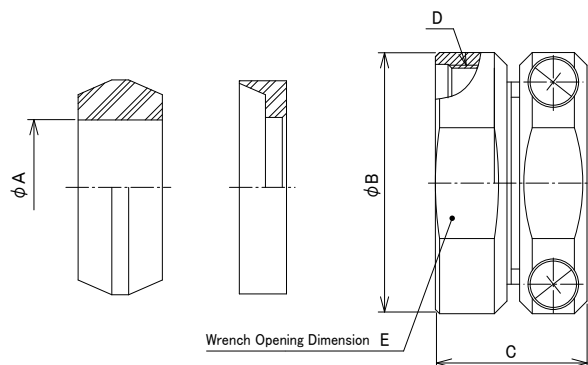

(Representative Example)

Unit : mm

Part No.	HRS No.	$\phi A$	$\phi B$	C	D	E	Purchase Unit
JR13WCC-4(31)	CL0114-2045-0-31	4	20	17	M16 × 0.75	17	20pcs per bag
JR13WCC-5(31)	CL0114-2046-3-31	5					
JR13WCC-6(71)	CL0114-2047-6-71	6					
JR13WCC-7(31)	CL0114-2048-9-31	7					
JR13WCC-8(31)	CL0114-2049-1-31	8					
JR13WCC-9(31)	CL0114-2050-0-31	9					
JR13WCC-10(31)	CL0114-2051-3-31	10					
JR16WCC-4(71)	CL0114-2052-6-71	4	23	17.5	M20 × 0.75	21	
JR16WCC-6(71)	CL0114-2053-9-71	6					
JR16WCC-8(71)	CL0114-2054-1-71	8					
JR16WCC-10(71)	CL0114-2055-4-71	10					
JR16WCC-12(71)	CL0114-2056-7-71	12					
JR25WCC-8(71)	CL0114-2063-2-71	8	31	18	M28 × 0.75	29	
JR25WCC-10(71)	CL0114-2064-5-71	10					
JR25WCC-12(31)	CL0114-2065-8-31	12					
JR25WCC-14(31)	CL0114-2066-0-31	14					
JR25WCC-16(31)	CL0114-2067-3-31	16					
JR25WCC-18(71)	CL0114-2068-6-71	18					

### Cord Clamp (Simplified Type)



JR13WCCA-6(71)

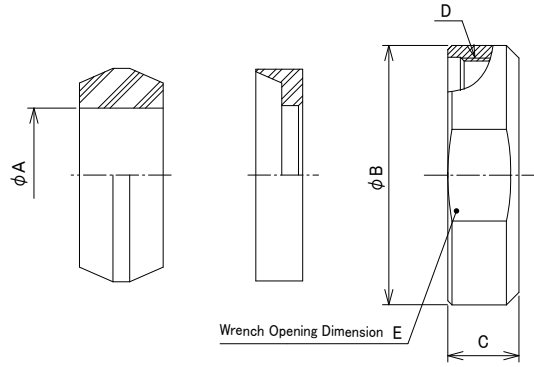

(Representative Example)

Unit : mm

Part No.	HRS No.	$\phi A$	$\phi B$	C	D	E	Purchase Unit
JR13WCCA-4(31)	CL0114-2069-9-31	4	19	7.5	M16 × 0.75	17	10pcs per bag
JR13WCCA-5(31)	CL0114-2070-8-31	5					
JR13WCCA-6(71)	CL0114-2071-0-71	6					
JR13WCCA-7(31)	CL0114-2072-3-31	7					
JR13WCCA-8(31)	CL0114-2073-6-31	8					
JR13WCCA-9(31)	CL0114-2074-9-31	9					
JR13WCCA-10(31)	CL0114-2075-1-31	10	23	8	M20 × 0.75	21	
JR16WCCA-4(71)	CL0114-2076-4-71	4					
JR16WCCA-6(71)	CL0114-2077-7-71	6					
JR16WCCA-8(71)	CL0114-2078-0-71	8					
JR16WCCA-10(71)	CL0114-2079-2-71	10	31	8.5	M28 × 0.75	29	
JR16WCCA-12(71)	CL0114-2080-1-71	12					
JR25WCCA-8(71)	CL0114-2087-0-71	8					
JR25WCCA-10(71)	CL0114-2088-3-71	10					
JR25WCCA-12(31)	CL0114-2089-6-31	12					
JR25WCCA-14(31)	CL0114-2090-5-31	14					
JR25WCCA-16(31)	CL0114-2091-8-31	16	18				
JR25WCCA-18(71)	CL0114-2092-0-71	18					

Note: The cable clamping force of the simplified type cord clamp is not very high, so please check the cable clamping force before use.

# Cap

## Cap (No Chain Type)



JR16WRC(31)

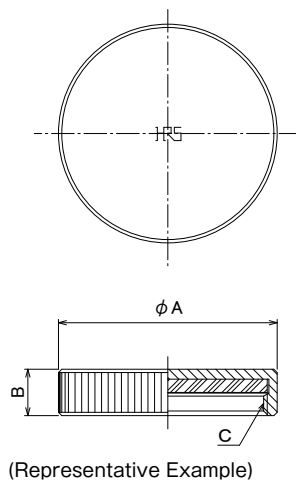

Unit : mm

Part No.	HRS No.	φ A	B	C	Purchase Unit
JR13WRC4 (Note 1)	CL0114-2192-5-00	21	7	M18 × 1	20pcs per bag
JR13WRC5 (Note 1)(Note 2)	CL0114-2105-0-00		7.5		
JR16WRC(31)	CL0114-2162-4-31	25	7	M22 × 1	
JR16WRC(75) (Note 1)	CL0114-2162-4-75			M30 × 1	
JR25WRC(31)	CL0114-2163-7-31	33	7.5	M30 × 1	30pcs per tray
JR25WRC(75) (Note 1)	CL0114-2163-7-75				20pcs per bag
JR25WRC5 (Note 1)(Note 2)	CL0114-2175-6-00				

Note 1: Waterproof gaskets with a silicone rubber specification  
 Note 2: Plastic shell

## Cap (Chain Type)



JR25WRC3

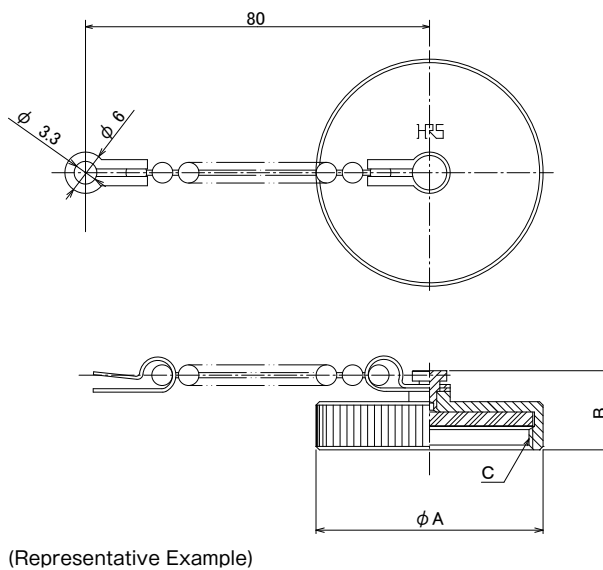

Unit : mm

Part No.	HRS No.	φ A	B	C	Purchase Unit
JR13WRC3 (Note)	CL0114-2170-2-00	21	11.5	M18 × 1	20pcs per bag
JR16WRC3 (Note)	CL0114-2171-5-00	25		M22 × 1	
JR25WRC3 (Note)	CL0114-2172-8-00	33		M30 × 1	

Note: Waterproof gaskets with a silicone rubber specification

## Crimp Contact

### For Contact Diameter $\phi 1$

#### Male Contact

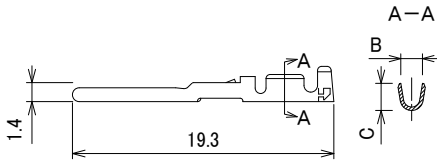

Unit : mm

Type	Part No.	HRS No.	B	C	Applicable Wire	Purchase Unit
Loose Contact	<a href="#">JRC-PC2-112</a>	CL0114-0243-3-00	1.6	2.0	20 to 24 AWG	100pcs per bag
	<a href="#">JRC-PC2-122</a>	CL0114-0244-6-00	1.45	1.5	24 to 28 AWG	
Reel Contact	<a href="#">JRC-PC2-212</a>	CL0114-0245-9-00	1.6	2.0	20 to 24 AWG	8,000pcs per reel
	<a href="#">JRC-PC2-222</a>	CL0114-0246-1-00	1.45	1.5	24 to 28 AWG	

Note: Refer to the Crimp Condition for the wire structure of the applicable wire.

The crimping condition table is available from the link of the product number.

(If you are using a cable that is not listed in Crimp Condition Table, please contact a Hirose sales representative.)

#### Female Contact

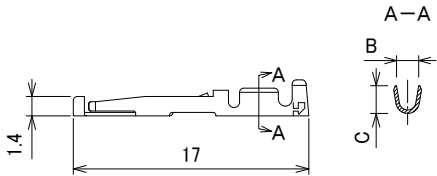

Unit : mm

Type	Part No.	HRS No.	B	C	Applicable Wire	Purchase Unit
Loose Contact	<a href="#">JRC-SC2-112</a>	CL0114-0247-4-00	1.6	2.0	20 to 24 AWG	100pcs per bag
	<a href="#">JRC-SC2-122</a>	CL0114-0248-7-00	1.45	1.5	24 to 28 AWG	
Reel Contact	<a href="#">JRC-SC2-212</a>	CL0114-0249-0-00	1.6	2.0	20 to 24 AWG	8,000pcs per reel
	<a href="#">JRC-SC2-222</a>	CL0114-0250-9-00	1.45	1.5	24 to 28 AWG	

Note: Refer to the Crimp Condition for the wire structure of the applicable wire.

The crimping condition table is available from the link of the product number.

(If you are using a cable that is not listed in Crimp Condition Table, please contact a Hirose sales representative.)

## Applicable Tools

Contact Dia.	Type	Part No.	HRS No.	Applicable Contact	Applicable Cable
φ 1	Manual Crimping Tool	HT802/RM-11	CL0150-0401-6-00	JRC-PC2-112	20 to 24 AWG
				JRC-SC2-112	
		HT802/RM-12	CL0150-0402-9-00	JRC-PC2-122	24 to 28 AWG
				JRC-SC2-122	
	Automatic Crimping Machine	CM-105C	CL0901-0001-0-00	-	-
	Applicator	AP105-JRC2-1	CL0901-2037-1-00	JRC-PC2-212	20 to 24 AWG
				JRC-SC2-212	
		AP105-JRC2-2	CL0901-2038-4-00	JRC-PC2-222	24 to 28 AWG
				JRC-SC2-222	
	Extraction Tool	RM-TP	CL0150-0008-7-00	-	-

## Crimping Precautions

### Items Required Prior to Crimping

The work-related documents shown below are required before starting the harness assembly.  
(The ● mark represents required documents.)

Please contact your Hirose sales representative if you do not have these documents.

Document Title	Description	Automatic Crimping Machine	Hand Crimping Tool	Remarks
(1) Main unit of crimping machine instruction manual	Explanation for main press machine unit	●	—	Bundled with the purchase of the main press machine unit.
(2) Applicator Spare Parts Identification	Explanation for Applicator installation	●	—	Bundled with the purchase of applicator.
(3) Crimp Conditions	Standard values of: Crimp height Tensile strength	●	—	
(4) Crimp Quality Standards	Various standards for crimping conditions	●	—	
(5) Operating Instructions for Hand Tool	Inspection items of f: Crimp height Tensile strength and others	—	●	Bundled with the purchase of hand tool.
(6) JR-W Cable Assembly Instruction	Cable Assembly procedure	●	●	Please refer to our website.

### Tools

- Use tools designated by Hirose when crimping.
- Crimping performed using tools other than those specified is outside the scope of warranty.
- The operating instructions are available for the crimping machine and the applicator. Be sure to carefully read the operating instructions manual before beginning work.

### Applicable Cables

Check that the cables to be used are within the applicable range.

If you intend to use a cable other than those recommended, contact a sales representative.

[Precautions]

- Cables applicable to crimp connectors are tin-plated stranded soft-copper wire.
- Avoid crimping solid wire, wires with polyester threads or tin coated wires.
- Avoid crimping two cables together.
- The crimp height setting values (Note) may vary depending on the difference in the core wire configuration even if the computed cross-sectional area is the same.

Note: The crimp height is an important item that determines crimp quality. Hirose conducts crimp testing on each wire in order to set the optimum crimp height accurately.

## Contact Arrangement and Specifications

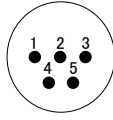
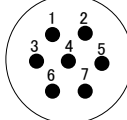
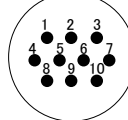
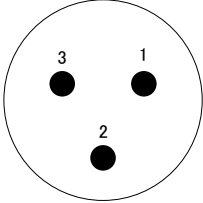
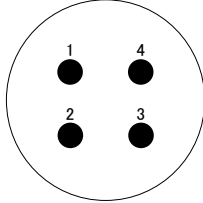
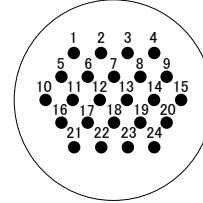
Shell Size	13		16	
	13, 16			
No. of Pos.	5	7	10	
Withstanding Voltage	1,000V AC / 1 minute			
Current Rating	5A	10A	5A	
Insulation Resistance	1,000M $\Omega$ Min.			
Contact Resistance	5m $\Omega$ Max.			
Solder Pot Inner Diameter	$\phi$ 1.1	$\phi$ 1.7	$\phi$ 1.1	
Shell Size	25			
				
No. of Pos.	3	4	24	
Withstanding Voltage	1,000V AC / 1 minute	3,000V AC / 1 minute	1,000V AC / 1 minute	
Current Rating	15A	30A	5A	
Insulation Resistance	1,000M $\Omega$ Min.	10,000M $\Omega$ Min.	1,000M $\Omega$ Min.	
Contact Resistance	3m $\Omega$ Max.	5m $\Omega$ Max.	5m $\Omega$ Max.	
Solder Pot Inner Diameter	$\phi$ 3 (Receptacle), $\phi$ 3.4 (Plug)	$\phi$ 3.4	$\phi$ 1.1	

Note 1: The figure above shows the connector with the female contact as seen from the mating side.

Note 2: Withstanding voltages indicate test voltage values.

## Precautions

1. Always switch off the circuit power before disconnecting or connecting the connectors.
2. Use connectors with female contacts on the power side of the circuit.
3. Ensure the coupling is fully locked.
4. Match the correct plug/receptacle for effective dust and water protection.
5. This series features silver-plated contacts. Silver may tarnish when exposed to sulfur gases under certain conditions such as:

- \* Dusty environments
- \* High sulfur gas concentration areas, e.g., near factory exhausts, automotive emissions
- \* Extreme temperature variations, high humidity, proximity to heaters
- \* Near rubber products, including adhesives.

Tarnishing does not affect electrical connections due to the contact pins' wiping effect.

Storage Instructions:

- \* Store in original or equivalent packaging.
- \* Temperature range: -10 to +60°C, with a maximum humidity of 85%.
- \* Store in a stable temperature and humidity environment.

Use products within 6 months of delivery. After 6 months, verify solderability before use.

'Storage' refers to keeping unused products in sealed packaging before PCB assembly.

## While Taking into Consideration

Specifications mentioned in this catalog are reference values.

When considering to order or use this product, please review the Drawing and Product Specifications sheets.

Use an appropriate cable when using the connector in combination with cables.

If considering usage of a non-specified cable, please contact your sales representative.

If assembly process is done by jigs & tools which are not identified by Hirose, the warranty of the product may be affected.

If considering usage for below mentioned applications, please contact your sales representative.

In cases where the application will demand a high level of reliability, such as automotive, medical instruments, public infrastructure, aerospace/defense etc. Hirose must review before assurance of reliability can be given.

**HIROSE****HIROSE ELECTRIC CO.,LTD.**2-6-3 Nakagawa Chuoh, Tsuzuki-Ku, Yokohama-Shi 224-8540, JAPAN  
<https://www.hirose.com>