

## Thick Film Chip Dividers, Medium Voltage

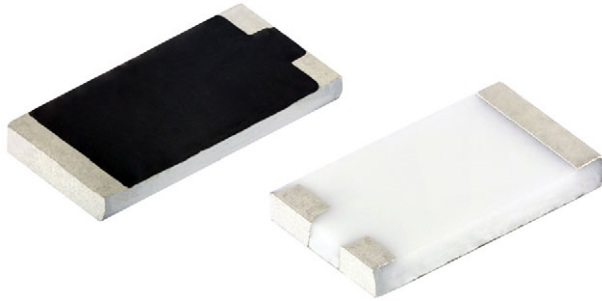

### FEATURES

- AEC-Q200 qualified
- Voltage up to 1415 V
- Precision to  $\pm 0.5\%$  with low TCR tracking to 10 ppm/ $^{\circ}\text{C}$  utilizing thick film technology
- Wide range of resistance value and ratios
- Termination style:  
3-sided wraparound termination
- Termination material:  
solder-coated nickel barrier
- Sulfur resistant verified by testing to EIA 977 test condition A
- Material categorization: for definitions of compliance please see [www.vishay.com/doc?99912](http://www.vishay.com/doc?99912)

 AUTOMOTIVE  
GRADE

**RoHS**  
COMPLIANT  
HALOGEN  
**FREE**

### LINKS TO ADDITIONAL RESOURCES



### APPLICATIONS

- Automotive:
  - EV charging for over voltage protection
  - Voltage dividers
  - On-board chargers
  - DC/DC converters
  - Battery management

### STANDARD ELECTRICAL SPECIFICATIONS

GLOBAL MODEL	CASE SIZE	POWER RATING $P_{70^{\circ}\text{C}}$ W	MAXIMUM WORKING VOLTAGE ( <sup>1</sup> ) V	RESISTANCE RANGE ( <sup>2</sup> ) $\Omega$	TOLERANCE ( <sup>3</sup> ) $\pm\%$	RATIO RANGE $(R_1 + R_2)/R_2$	TCR TRACKING ( $-55^{\circ}\text{C}$ to $+155^{\circ}\text{C}$ ) $\pm$ ppm/ $^{\circ}\text{C}$
CDMA	2512	1	1415	500K to 50M	0.5, 1, 2, 5, 10	100:1 to 600:1	10 to 50

#### Notes

- (1) Continuous working voltage shall be  $\sqrt{P \times R}$  or maximum working voltage, whichever is less
- (2) Resistance values are calibrated at 100 V<sub>DC</sub>. Calibration at other voltages available upon request
- (3) Contact factory for tighter tolerances

### GLOBAL PART NUMBER INFORMATION

 New Global Part Numbering: **CDMA20K0J1000GEB** (preferred part number format)

<b>C</b>	<b>D</b>	<b>M</b>	<b>A</b>	<b>2</b>	<b>0</b>	<b>K</b>	<b>0</b>	<b>J</b>	<b>1</b>	<b>0</b>	<b>0</b>	<b>0</b>	<b>G</b>	<b>E</b>	<b>B</b>		
GLOBAL MODEL	RESISTANCE VALUE ( $R_1$ )	TOLERANCE	RATIO $(R_1 + R_2) / R_2$	RATIO TOLERANCE	SOLDER TERMINATION	PACKAGING	SPECIAL										
<b>CDMA</b> = CDMA2512	K = k $\Omega$ M = M $\Omega$ <b>20K0</b> = 20 k $\Omega$ <b>800K</b> = 800 k $\Omega$ <b>1M00</b> = 1 M $\Omega$	<b>D</b> = $\pm 0.5\%$ <b>F</b> = $\pm 1\%$ <b>G</b> = $\pm 2\%$ <b>J</b> = $\pm 5\%$ <b>K</b> = $\pm 10\%$	3 digit significant figure, followed by a multiplier <b>1000</b> = 100:1 <b>2000</b> = 200:1	<b>D</b> = $\pm 0.5\%$ <b>F</b> = $\pm 1\%$ <b>G</b> = $\pm 2\%$ <b>H</b> = $\pm 3\%$ <b>J</b> = $\pm 5\%$	<b>E</b> = Sn100	<b>B</b> = bulk (250 pcs max.) <b>F</b> = T / R (full reel) <b>1</b> = T / R (1000 pcs) <b>5</b> = T / R (500 pcs) <b>T</b> = T / R (250 pcs min.)											

#### Note

- For additional information on packaging, refer to the "Surface-Mount Resistor Packaging" document ([www.vishay.com/doc?31543](http://www.vishay.com/doc?31543))

<b>VOLTAGE COEFFICIENTS AND RATIO TRACKING INFORMATION (Typical)</b>			
RESISTANCE ( $\Omega$ )	RATIO (MAXIMUM)	VCR (ppm/V)	TCR TRACKING (ppm/ $^{\circ}$ C) -55 $^{\circ}$ C to +155 $^{\circ}$ C
500K	100:1	-10	$\pm 20$
15M	250:1	-10	$\pm 10$
50M	600:1	-10	-50 to 0

**Note**

- Contact factory for other ratios

<b>MATERIAL SPECIFICATIONS</b>	
Resistive element	Ruthenium oxide
Encapsulation	Epoxy
Substrate	96 % alumina
Termination	Solder-coated nickel barrier terminations standard
Solder finish	Pure tin

<b>ENVIRONMENTAL SPECIFICATIONS</b>	
Operating temperature	-55 $^{\circ}$ C to +155 $^{\circ}$ C
Life	Less than 0.5 % change when tested at full rated power

**Note**

- Reference only: not for all values specified. Consult factory for your size and value

<b>DIMENSIONS</b> in inches (millimeters)							
TERMINATION	LENGTH (L) $\pm 0.006$ (0.152)	WIDTH (W) $\pm 0.006$ (0.152)	THICKNESS (T) $\pm 0.005$ (0.127)	A $\pm 0.005$	B $\pm 0.005$	C $\pm 0.005$	E $\pm 0.010$
Style A (3-sided wraparound)	0.250	0.126	0.025	0.025	0.025	0.040	0.046

<b>RECOMMENDED SOLDER PAD LAYOUT</b>							
MODEL	DIMENSIONS in inches (millimeters)						
	A	B	C	D1	D2	E	F
CDMA2512	0.275 (6.99)	0.126 (3.20)	0.190 (4.83)	0.050 (1.27)	0.035 (0.89)	0.040 (1.02)	0.046 (1.17)

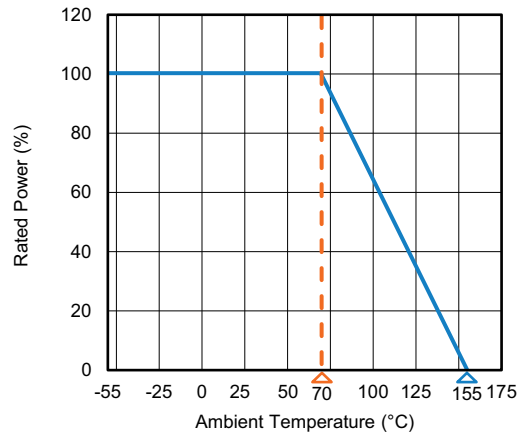
**DERATING CURVE**

**Note**

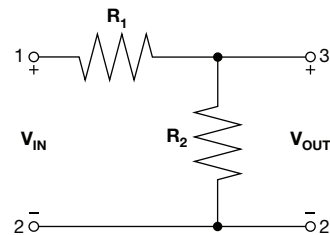
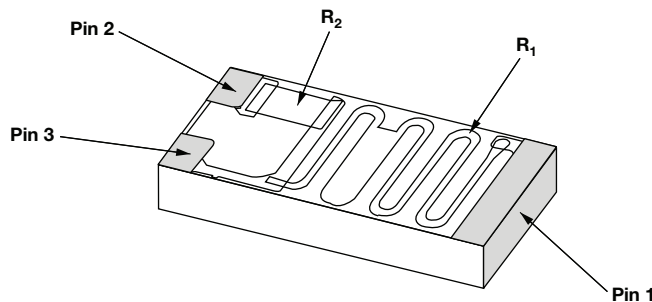
- Reference only: not for all values specified. Consult factory for your specific value

**SCHEMATIC**

**PERFORMANCE**

TEST	CONDITIONS OF TEST	TEST LIMITS
High temperature exposure (storage)	MIL-STD-202, method 108, 2000 h at $T = 155\text{ }^{\circ}\text{C}$ at 0 % power	$\pm 1.0\%$
Thermal shock	JESD22 method JA-104, 2000 cycles ( $-55\text{ }^{\circ}\text{C}$ to $+150\text{ }^{\circ}\text{C}$ ), dwell time = 15 min, maximum transfer time = 20 s air to air	$\pm 1.0\%$
Moisture resistance	MIL-STD-202, method 106	$\pm 1.0\%$
Biased humidity	MIL-STD, method 103, 2000 h $85\text{ }^{\circ}\text{C} / 85\%$ RH Note: specified conditions: 10 % of rated voltage	$\pm 2.0\%$
Operational life	MIL-STD-202, method 108, 2000 h, $T_a = 125\text{ }^{\circ}\text{C}$ at rated power	$\pm 1.0\%$
Resistance to solvents	MIL-STD-202, method 215	No damage to parts
Mechanical shock	MIL-STD-202, method 213, figure 1, SMD, condition C	$\pm 0.5\%$
Vibration	MIL-STD-202, method 204, 5 $g$ 's for 20 minutes, 12 cycles each of 3 orientations	$\pm 0.5\%$
Resistance to solder heat	MIL-STD-202, method 210, condition J	$\pm 1.0\%$
Solderability	J-STD-002, method B1, 4 h at $155\text{ }^{\circ}\text{C}$ dry heat, solder at $245\text{ }^{\circ}\text{C}$ , magnification 50 x	> 95 % coverage
Flammability	UL 94	V-0
Board flex	AEC-Q200-005 2 mm min.	$\pm 1.0\%$
Terminal strength (SMD)	AEC-Q200-006 force of 1.8 kg for 60 s	$\pm 1.0\%$



## **Disclaimer**

ALL PRODUCT, PRODUCT SPECIFICATIONS AND DATA ARE SUBJECT TO CHANGE WITHOUT NOTICE TO IMPROVE RELIABILITY, FUNCTION OR DESIGN OR OTHERWISE.

Vishay Intertechnology, Inc., its affiliates, agents, and employees, and all persons acting on its or their behalf (collectively, "Vishay"), disclaim any and all liability for any errors, inaccuracies or incompleteness contained in any datasheet or in any other disclosure relating to any product.

Vishay makes no warranty, representation or guarantee regarding the suitability of the products for any particular purpose or the continuing production of any product. To the maximum extent permitted by applicable law, Vishay disclaims (i) any and all liability arising out of the application or use of any product, (ii) any and all liability, including without limitation special, consequential or incidental damages, and (iii) any and all implied warranties, including warranties of fitness for particular purpose, non-infringement and merchantability.

Statements regarding the suitability of products for certain types of applications are based on Vishay's knowledge of typical requirements that are often placed on Vishay products in generic applications. Such statements are not binding statements about the suitability of products for a particular application. It is the customer's responsibility to validate that a particular product with the properties described in the product specification is suitable for use in a particular application. Parameters provided in datasheets and / or specifications may vary in different applications and performance may vary over time. All operating parameters, including typical parameters, must be validated for each customer application by the customer's technical experts. Product specifications do not expand or otherwise modify Vishay's terms and conditions of purchase, including but not limited to the warranty expressed therein.

Hyperlinks included in this datasheet may direct users to third-party websites. These links are provided as a convenience and for informational purposes only. Inclusion of these hyperlinks does not constitute an endorsement or an approval by Vishay of any of the products, services or opinions of the corporation, organization or individual associated with the third-party website. Vishay disclaims any and all liability and bears no responsibility for the accuracy, legality or content of the third-party website or for that of subsequent links.

Vishay products are not designed for use in life-saving or life-sustaining applications or any application in which the failure of the Vishay product could result in personal injury or death unless specifically qualified in writing by Vishay. Customers using or selling Vishay products not expressly indicated for use in such applications do so at their own risk. Please contact authorized Vishay personnel to obtain written terms and conditions regarding products designed for such applications.

No license, express or implied, by estoppel or otherwise, to any intellectual property rights is granted by this document or by any conduct of Vishay. Product names and markings noted herein may be trademarks of their respective owners.